

**Industrial  
UPS**

**Denby**  
丹能 @POWER

## **LF33 SERIES UPS**



**10–300kVA**

# Table of Contents

<b>1. Introduction</b>	<b>1</b>
1.1 Overview	1
1.2 Basic structure	1
1.3 Working mode	1
1.4 Overview	5
<b>2. Important Safety Warning</b>	<b>6</b>
2.1 Conventions and used symbols	6
2.2 Safety instructions	7
<b>3. Installation</b>	<b>10</b>
3.1 Basic requirement	10
3.2 Disassembling and moving	11
<b>4. Electrical connection</b>	<b>13</b>
4.1 Power connection	13
4.2 Communication	16
<b>5. Commissioning</b>	<b>20</b>
5.1 Startup procedure	20
5.2 Shutdown procedure	20
5.3 Maintenance bypass operation	21
<b>6. Interface</b>	<b>21</b>
6.1 Battery test	21
6.2 Language settings	22
6.3 Date & time settings	22
6.4 Configure display settings	23
6.5 Change the display password	23
6.6 Network settings	24
6.7 Display Calibration	25
6.8 Parameter settings	25
6.9 Battery Settings	26
6.10 Mode settings	27
6.11 Parallel settings	29
6.12 Battery test settings	29
6.13 Dry contact settings	31
6.14 Output dry contact settings	31
6.15 Fault alarm	32
6.16 Clear event log	33
6.17 Clear settings log	33
6.19 Clear fault status	33
<b>7. Maintenance</b>	<b>34</b>
7.1 System maintenance	34
7.2 Battery maintenance	34
<b>8. Trouble shooting</b>	<b>35</b>
8.1 Warning code	35
8.2 Fault code	38
<b>9. Specification</b>	<b>40</b>
<b>10. Parallel Installation Guide</b>	<b>43</b>
10.1 Introduction	43

<i>10.2 Parallel Kit Overview</i> .....	43
<i>10.3 Parallel setting and LCD display</i> .....	47
<i>10.3 Specification</i> .....	48
<i>10.4 Trouble shooting</i> .....	49

# 1. Introduction

## 1.1 Overview

This UPS series is a double conversion system with sinewave output. It supplies continuous, stable, clean power for commercial and industrial environments. When the utility is lost accidentally, the UPS system will use the power from battery to output without interruption.

This system is applied an advanced digital controller to control the double conversion system, and with an isolated transformer at the output to protect the load and the UPS itself. The UPS is also built-in user-friendly LCD interface and multiple communications including Modbus, RS-232 and intelligent slot. With free download software, this UPS provides complete power solution of monitoring and controlling remotely.

## 1.2 Basic structure

The whole system consists of REC module, INV module, static bypass, maintain bypass and battery controller. The output of the UPS are switched over to either line input or bypass input with two SCRs operated in parallel. The basic structure is shown as below:

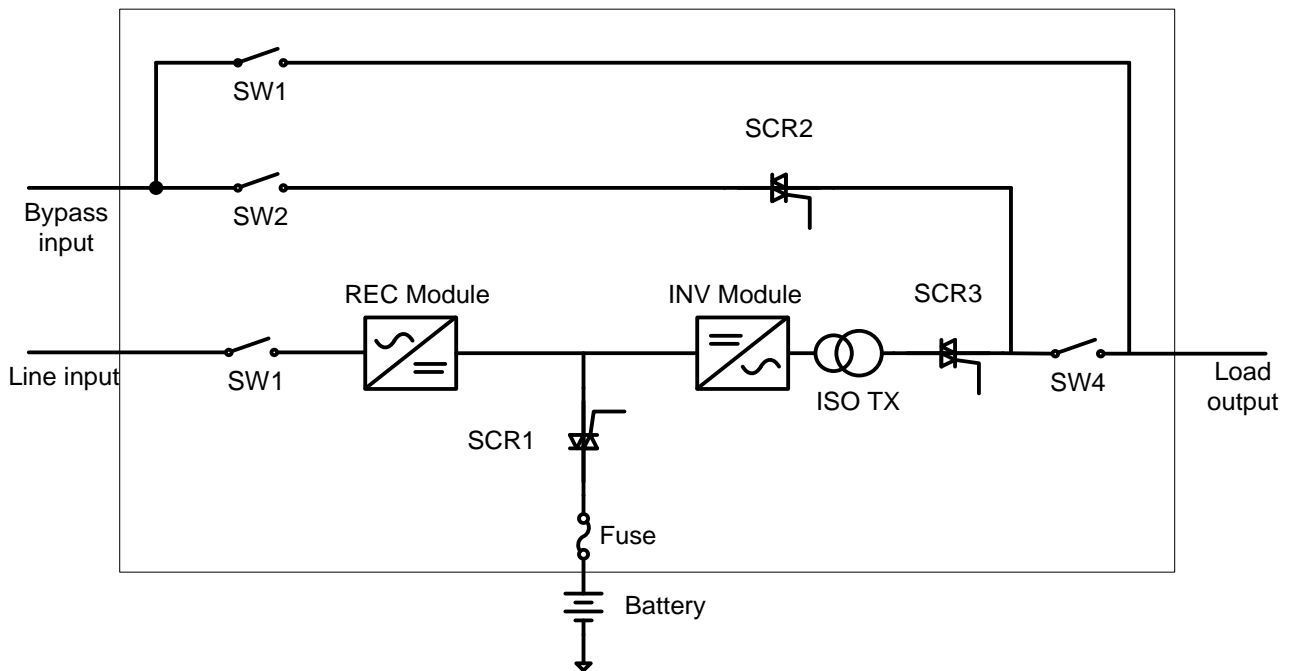

## 1.3 Working mode

This part will introduce the working mode of the UPS system.

### 1.3.1 Line mode

When the UPS is working in line mode, the AC input will be rectified by REC module, and then be converted to the output via INV module. Meanwhile, the battery is being charged. At this time, static bypass is in standby.

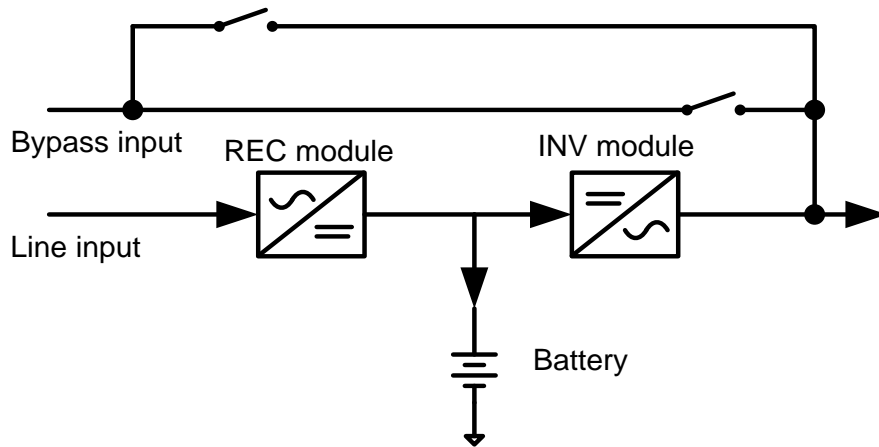

### 1.3.2 Battery mode

When the utility fails, the UPS will transfer to battery mode without interruption. The UPS converts the power from battery to output. At this time, static bypass is still in standby. If the utility is recovered, the UPS will transfer back to line mode again.

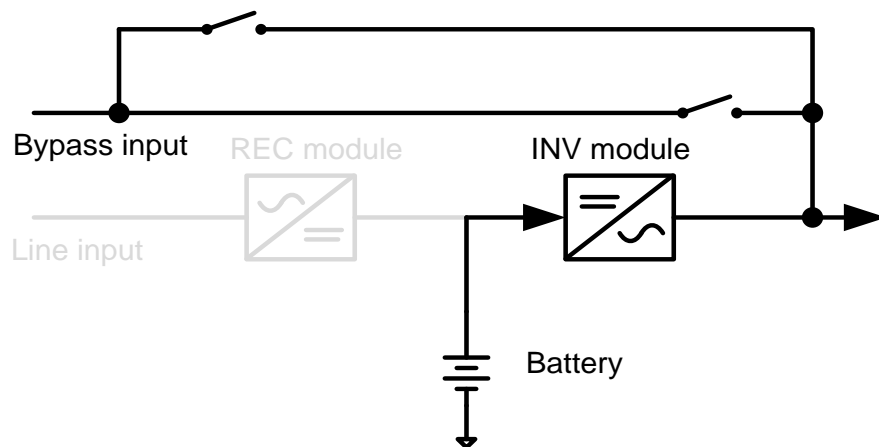

### 1.3.3 Static bypass mode

Bypass mode can be enabled or disabled by user setting. The default setting is enabled. The UPS system will work in bypass mode when the following conditions occur.

- The UPS system doesn't turn on.
- The UPS is overload in line mode.
- The rectifier or inverter module is abnormal.
- The utility fails and the battery is discharged to low level.

When above mentioned situation is eliminated, the UPS will transfer back to line mode or battery mode.

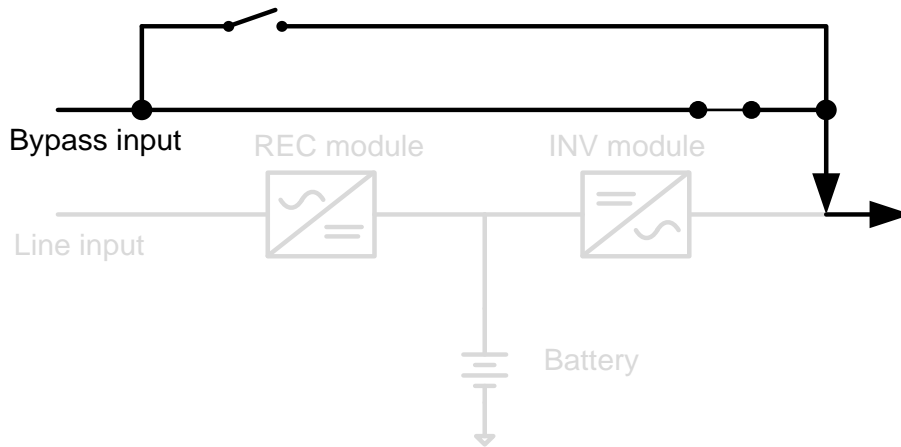

### 1.3.4 ECO MODE

ECO mode can be enabled or disabled by user setting. The default setting is disabled. If it's required to have high efficiency performance instead of the high power quality, it's better to enable "ECO mode".

In this mode, load will be supported via Bypass input when utility quality is OK. And the Line input will still be operated to charge battery and INV module is in standby status with switch opened. When Bypass input is lost, the system will transfer to line mode or battery mode and the transfer time is less than 10ms. When Bypass input is restored, the system transfers back to bypass mode again. This ECO mode operation greatly improves system efficiency.

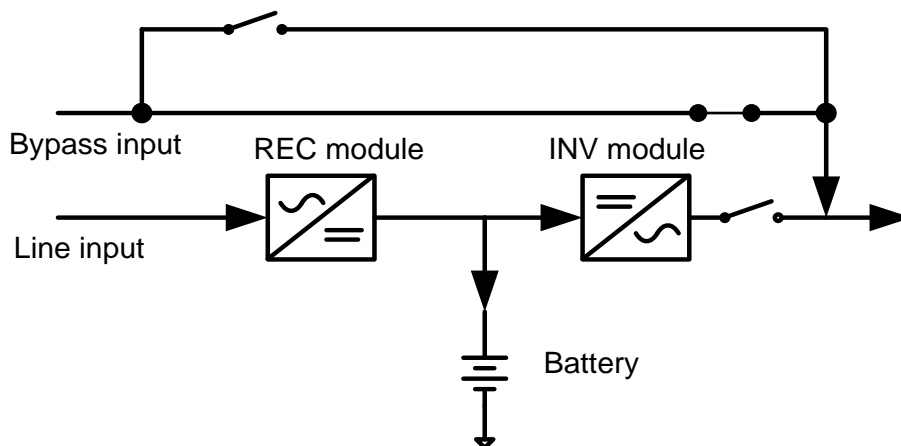

### 1.3.5 Maintain bypass mode

When the UPS needs maintenance and load needs uninterruptible power, the users can firstly transfer the inverter to bypass mode, and then switch on maintain bypass breaker. After that, switch off all other breakers and switches. In this condition, the utility can still power the load and users can maintain the UPS.

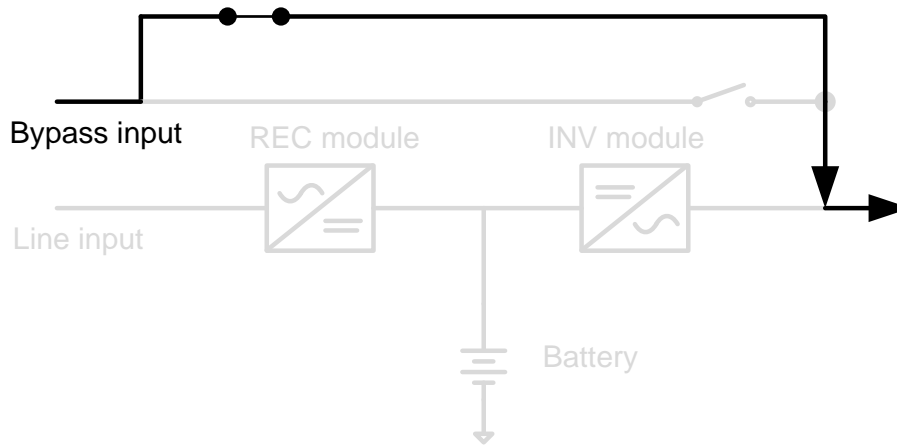

### 1.3.6 Other modes

Except mentioned modes above, there are standby mode, power-off mode and fault mode.

There is no output in standby mode, but the utility will charge battery. If the UPS stays in standby mode for a while without utility and load connection, the UPS will transfer to power-off mode. At this time, the UPS can't be turned on by pressing ON button. Please kindly wait for 5 minutes to allow UPS completely off itself. After 5 minutes, UPS can be restarted by pressing ON button.

The UPS will transfer to fault mode if a fault occurs in the UPS. When some minor faults occur, the UPS still can transfer to bypass mode if bypass input is available. When some severe faults occur, it won't be eliminated until the users restart the UPS.

### 1.3.7 Dual input source

The line input and bypass input are separated routes in this UPS. Users can apply different power sources into these two input routes and set up a dual-input system. Users also can connect the same power source to these two inputs. Once the utility fails, no Line input and bypass input is available at the same time. Then, it will transfer to battery mode.

### 1.3.8 Reverse phase sequence operation

When the phase sequence of the line input is reversed, the UPS can still work in the line mode with "Line phase error" warning. If the bypass input connects to the line input with the same AC source, it will alarm with "Bps.phase error" warning and can't turn into bypass mode.

### 1.3.9 No neutral operation

When the line input disconnects from the neutral, the UPS can still work in the line mode.

## 1.4 Overview

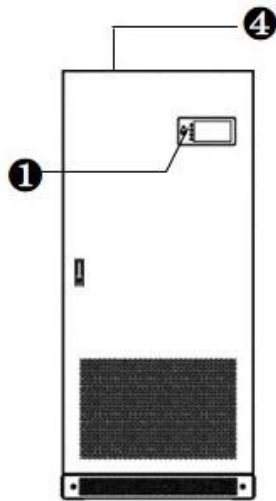

10K-80K

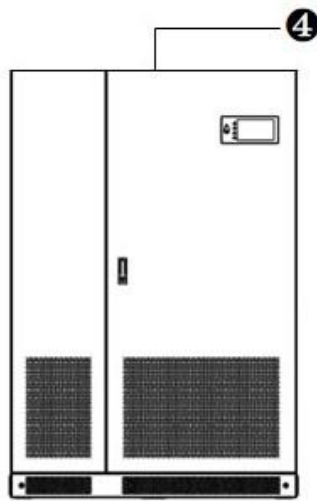

100K-120K

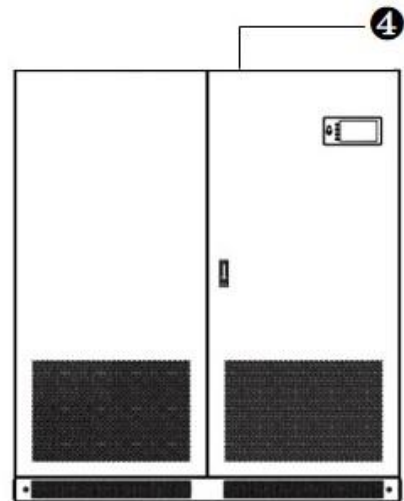

160K-300K

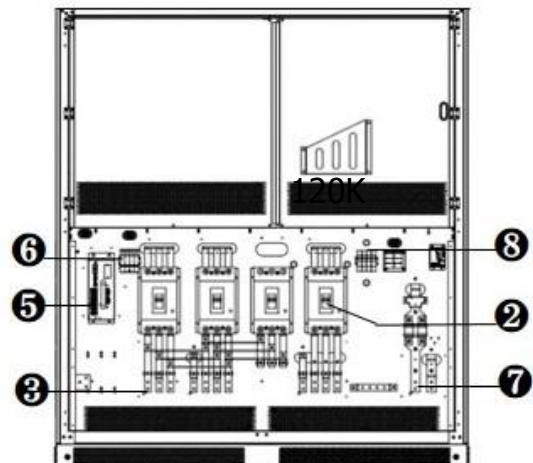
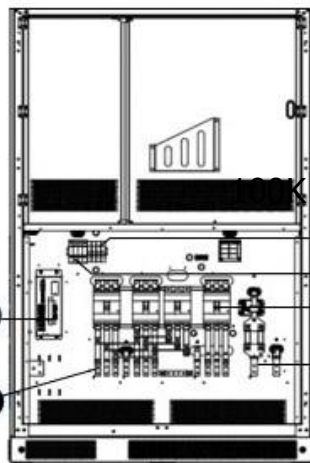
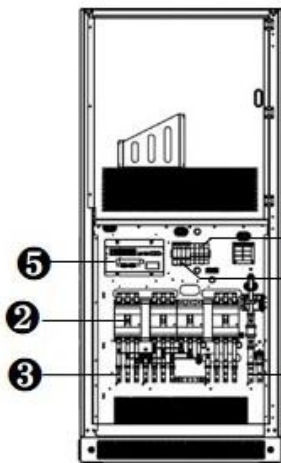

1) Interface

2) Terminals

3) Breaker and switch

4) Fans

5) Lightning protection device

6) Battery input terminal

7) SPS fuse















## 2. Important Safety Warning

### 2.1 Conventions and used symbols

#### Conventions used:

**WARNING!** Warnings identify conditions or practices that could result in personal injury;

**CAUTION!** Caution identify conditions or practices that could result in damaged to the unit or other equipment connected.

	Warning, risk of electric shock
	Warning, risk of danger
	Warning, risk of electric shock, energy storage timed discharge
	Refer to the operating instructions
	Warning, danger of the possible fall down of the equipment
	Warning, Danger of fan's rotation.
	Warning, hot surface
	Protective conductor terminal
	Earth (ground) terminal
	Direct current
	Alternating current
	Both direct and alternating current
	Three-phase alternating current
	Three-phase alternating current with neutral conductor
	Preservation of the environment: the users can contact with their provider or with the pertinent local authorities to be informed on how and where they can take the product to be recycled and/or disposed correctly.

## 2.2 Safety instructions



**WARNING!** Before installing and using this equipment, read all instructions and cautionary markings on the UPS and this manual. Store the manual where it can be accessed easily.



**WARNING!** This manual is for qualified personnel. The tasks described in this manual may be performed by qualified personnel only.



**WARNING!** This equipment must be installed by qualified person.



**WARNING!** An earth cable whose cross section should be the same as or greater than the power supply cable has to be connected to the protective earth connection.



**WARNING!** Make sure the UPS is isolated and protective earth correctly connected at installing and before operating the UPS.



**CAUTION!** This UPS should use for an IT distribution system.



**CAUTION!** The UPS's output neutral is same as the input neutral(Non isolate type). For the correct operation of the UPS, the input neutral cable should be connected. It may cause power loss without input neutral.



**CAUTION!** Please transport the UPS with packaged from factory.



**WARNING!** Pay attention to the slope of the ground and surface to avoid fall down when moving the equipment.



**WARNING!** This equipment is heavy. Do not lift too heavy without help.



**CAUTION!** The UPS can only working on dry condition. Shut down the UPS if any liquid flows into the UPS and dry it with absorbent cloth. Please use dry cloth when clean the UPS.



**CAUTION!** Please charge the battery first if using the UPS for first time or no using the UPS for a long period of time (6 months maximum).



**WARNING!** Never manipulate the equipment with wet hands.



**CAUTION!** To avoid a risk of fire and electric shock, make sure that existing wiring is in good condition and that the wire is not undersized. Do not operate the Inverter with damaged or substandard wiring.



**WARNING!** When the UPS shut down the power supply to the load because of EPO signal trigger, the equipment has power supply yet. To shut down the equipment's power, please turn off all the input power.



**WARNING!** Authorized service personnel should reduce the risk of electrical shock by disconnecting both the AC and DC power from the UPS before attempting any maintenance or cleaning or working on any circuits connected to the inverter. Turning off controls will not reduce this risk. Internal capacitors can remain charged after disconnecting all sources of power.



**CAUTION!** Do not open, disassemble or modify the equipment yourself. It contains no user-serviceable parts. Attempt to service this equipment yourself may cause a risk of electrical shock or fire and will void the warranty from the manufacturer.



**CAUTION!** Shut down the UPS If any smoke or gas exhausts from the UPS.



**WARNING!** Battery circuit is not isolated; it is dangerous to touch any part of the batteries.



**CAUTION!** When batteries are replaced, the complete battery set has to be replaced and do not reuse faulty batteries.



**CAUTION!** Do not expose the batteries in a fire or to high temperatures. Batteries may explode.



**CAUTION!** Batteries involve a serious risk for health and environment. Their disposal should be done in accordance with the existing regulations.



**WARNING!** Under high temperature environment, the case of this equipment could be hot enough to cause skin burns if accidentally touched. Ensure that this inverter is away from normal traffic areas.



**CAUTION!** Use only recommended accessories from installer. Otherwise, not-qualified tools may cause a risk of fire, electric shock, or injury to persons.



**CAUTION!** To reduce risk of fire hazard, do not cover or obstruct the equipment.

### 3. Installation

#### 3.1 Basic requirement

- Ambient temperature: 0°C~+55°C
- Storage temperature: -15°C ~ 60°C
- Relative humidity: 5% ~ 95%
- Altitude: If the UPS is installed within 1000m, the UPS power will not be derated. When the height is over 1000m, the output power will be derated by following the table.

Altitude(m)	1000	1500	2000	2500	3000	3500	4000	4500	5000
Coefficient	100%	95%	91%	86%	82%	78%	74%	70%	67%

- Vertical: No vibration and the degree of deviation from vertical shouldn't be more than 5°.
- Space: It's requested to have a clearance of approx. 100 cm to the front and back of the unit and approx. 50 cm to the side. The left, right and back sides can be side by side with walls or other objects. Do not place any objects on the top of the UPS, with a ventilation space of at least 100cm; so as not to affect the ventilation of the system.

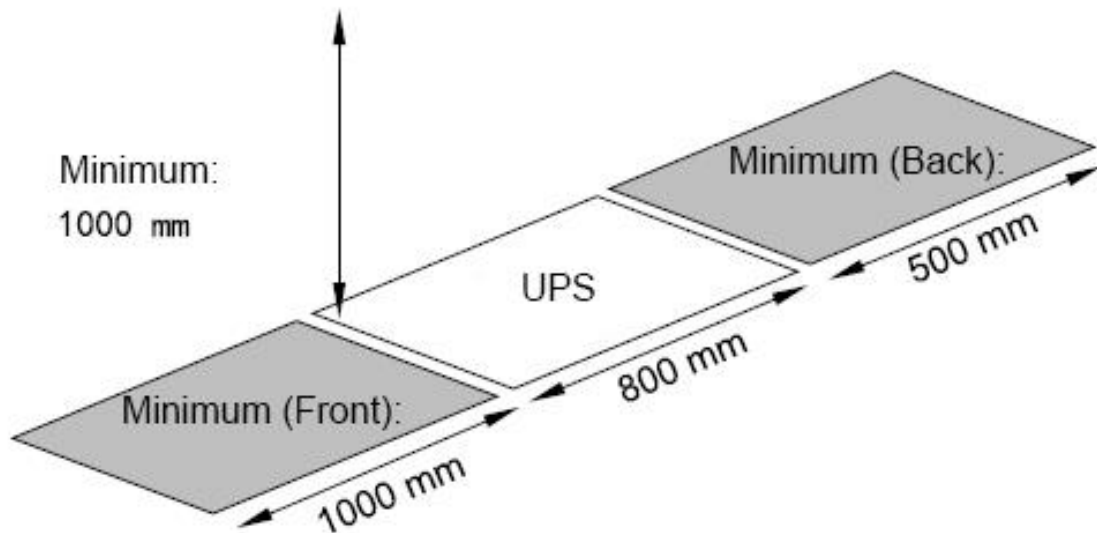

The UPS should be installed in the environment with free ventilation, less dust, optimum ambient temperature and humidity.

The recommended ambient temperature is 20°C~25°C with 50% humidity.

**Caution!** It's NOT allow to have flammable, explosive or corrosive gas or liquid in installation environment. It is forbidden to install in a metal conductive dust environment.

### 3.2 Disassembling and moving

- Please check if any damage on the carton before open.
- Then follow below steps to remove UPS from the carton and the pallet.

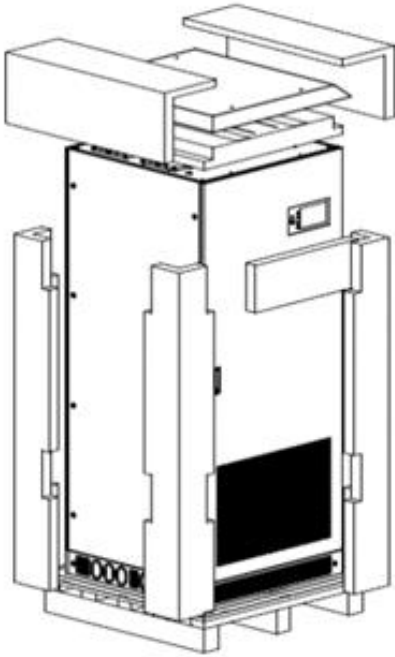

1. Remove the cartons and foam.

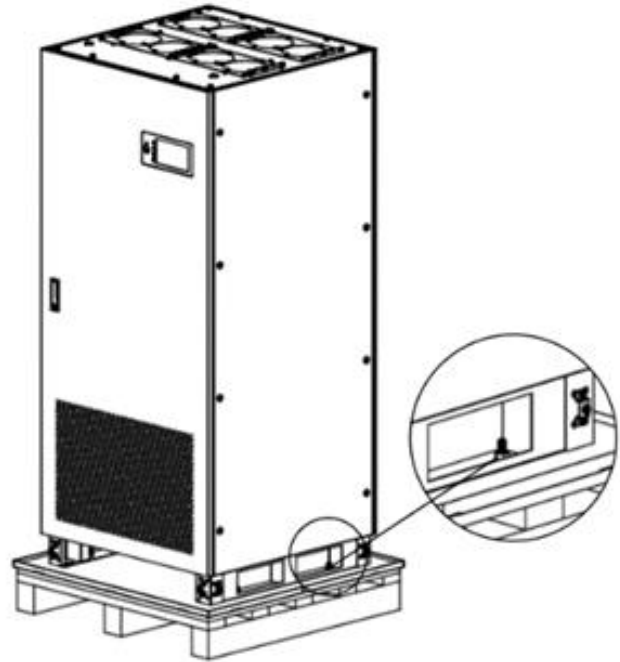



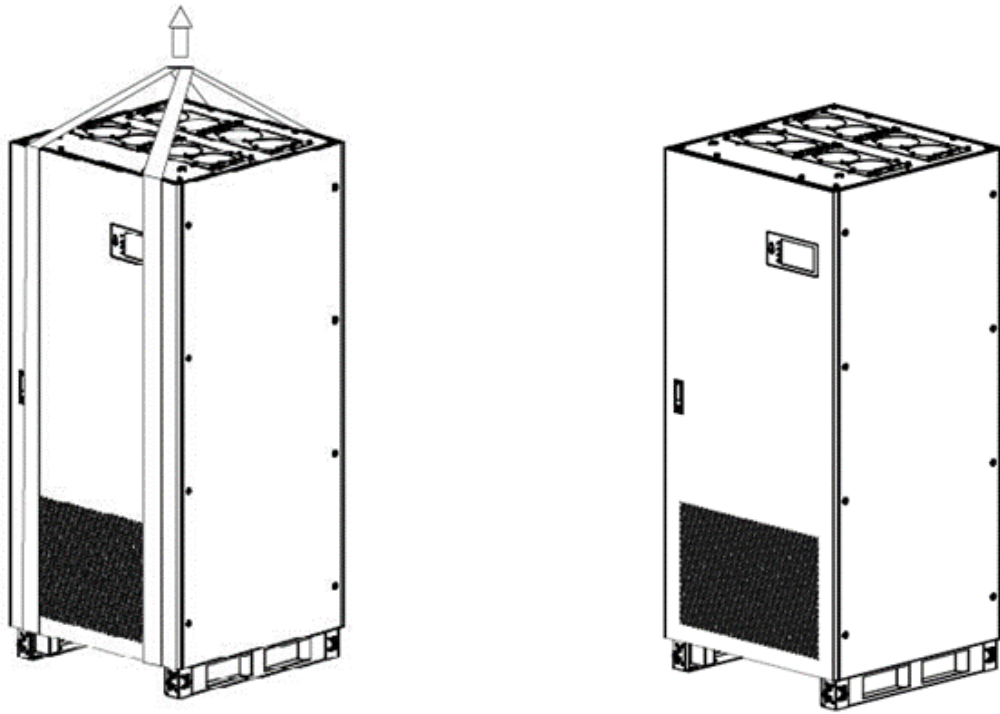

2. Remove the nuts showed in the figure.



3. Preparing two cables. The length of two cables is about 6 meters and the bearing should be at least 3 tons.
4. Fix the UPS with cables. Use the hoist to lift up the UPS and place it on the ground.

➤ After the UPS is removed from pallet, please inspect the unit and package contents. Be sure that nothing inside the package is damaged. You should have received the following items inside of package:

				
<b>User manual</b>	<b>Certification</b>	<b>Warranty card</b>	<b>RS-232 cable</b>	<b>USB cable</b>

## 4. Electrical connection

### 4.1 Power connection

All the connectors are accessible by front panel of the UPS. Simply open the front door for wire connection. Refer below diagrams for inside panel for whole series.

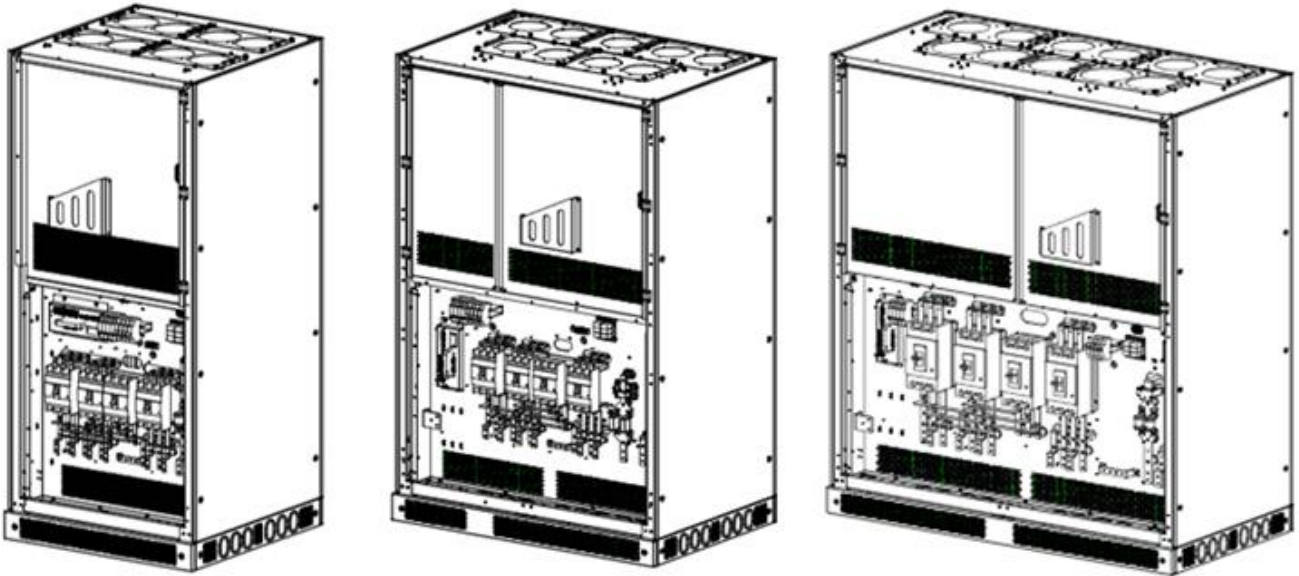

10K~80K

100K~120K

160K~300K

After remove the cover plate, the wire terminals of each model are shown as below:

➤ 10K~300K

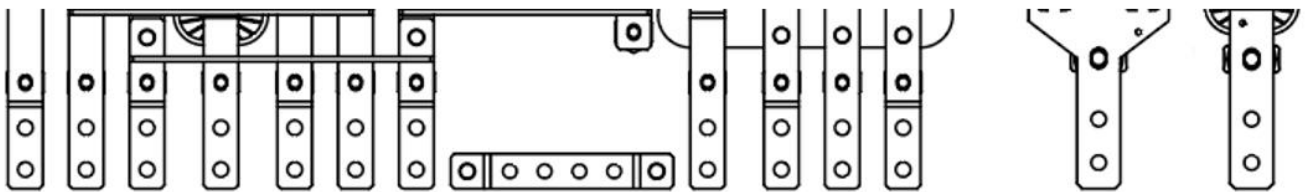

L1	L2	L3
AC INPUT		

N	L1	L2	L3
BYPASS INPUT			

N	L1	L2	L3
AC OUTPUT			

-	+
BATTERY	

**The connection point of the ground terminal is shown as below:** Located in the middle position below the copper sheet.

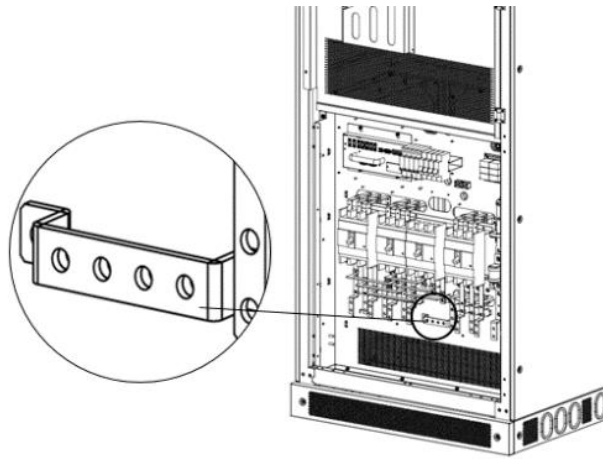

The specifications of switches and fuses installed on the internal input and output lines of the UPS are for reference (the actual specifications are subject to the actual product).

**Caution!** Before the UPS is installed, please make sure that all the circuit breakers are in the off position.

UPS Model	Breaker				Battery Fuse
	LINE INPUT	BYPASS	M-BYPASS	OUTPUT	
LF3310	30A/3P	30A/3P	30A/3P	30A/3P	100A
LF3320	60A/3P	60A/3P	60A/3P	60A/3P	100A
LF3330	100A/3P	60A/3P	60A/3P	60A/3P	160A
LF3340	125A/3P	125A/3P	125A/3P	125A/3P	200A
LF3360	150A/3P	150A/3P	150A/3P	150A/3P	315A
LF3380	200A/3P	200/3P	200A/3P	200A/3P	350A
LF33100	250A/3P	250A/3P	250A/3P	250A/3P	250A*2
LF33120	250A/3P	250A/3P	250A/3P	250A/3P	250A*2
LF33160	400A/3P	400A/3P	400A/3P	400A/3P	350A*2
LF33200	400A/3P	400A/3P	400A/3P	400A/3P	350A*2
LF33250	500A/3P	400A/3P	400A/3P	400A/3P	800A
LF33300	600A/3P	500A/3P	500A/3P	500A/3P	600A*2

**The recommended specifications of UPS upstream cables are shown in the following table:**

UPS Model	Input (mm <sup>2</sup> )	Input PE (mm <sup>2</sup> )	Bypass/Output (mm <sup>2</sup> )	Bypass PE (mm <sup>2</sup> )	Null line (mm <sup>2</sup> )	DC+/DC- (mm <sup>2</sup> )	DC PE (mm <sup>2</sup> )
LF3310	16	16	16	16	16	16	16
LF3320	16	16	16	16	16	16	16
LF3330	16	16	16	16	25	25	16
LF3340	25	16	16	16	35	35	16
LF3360	35	16	25	16	50	50	25
LF3380	35	16	35	16	50	70	35
LF33100	50	25	50	25	70	70	35
LF33120	70	35	50	25	70	2*50	50
LF33160	2*50	50	70	35	70	2*70	70
LF33200	2*70	70	2*50	50	2*50	2*95	95
LF33250	2*95	95	2*70	70	2*70	3*70	95
LF33300	3*95	2*70	2*95	95	2*95	3*95	2*70

**The recommended sizes of the screws and ring terminals are listed as below:**

Cable size (mm <sup>2</sup> )	Screw size	Terminal model
10	M8	TLK-10-8
16	M8	TLK-16-8
25	M8	TLK-25-8
35	M8	TLK-35-8
50	M8	TLK-50-8
70	M8	TLK-70-8
95	M8	TLK-95-8

**Recommended battery pack capacity:**

Model(P.C.)	10~40KVA	60~80KVA	100~120KVA	160~300KVA
Battery capacity	100AH	200AH	400AH	600AH

**Caution!** Please set up suitable charging current and battery numbers based on specifications. Wrong configuration will shorten lifecycle of battery.

Check the phase sequence of LINE INPUT, BYPASS and OUTPUT; Check the polarity of the battery cables; Make sure all the connected cables are screwed tightly.

## 4.2 Communication

The definition of the communication port is shown in the figure below. The user can refer to this section to implement various communication and remote monitoring functions when installing and using it.

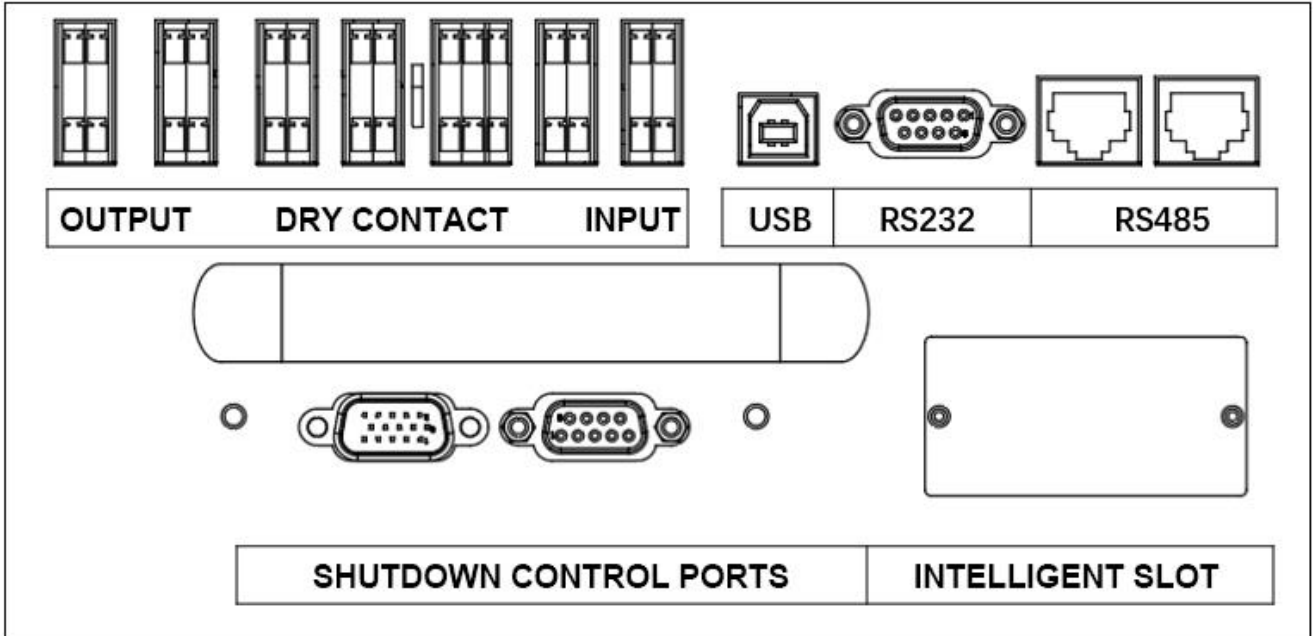

### 4.2.1 Intelligent slot

The intelligent slot can provide SNMP solution for remote monitor. Please request the supplier for detail information.

### 4.2.2 Dry contact

There are 5 output, 4 input dry contacts and 1 battery switch trip contact. The detailed functions are listed as below.

DO2-DRY CONTACT UPS ALARM DO2-COMMOMN PORT	4 2	1 3	CN17
DO4-DRY CONTACT UPS GRID-FALL DO4-COMMOMN PORT	4 2	1 3	CN18
DO5-DRY CONTACT UPS.BYPEN DO5-COMMOMN PORT	4 2	1 3	CN19
NTC	4 2	1 3	CN21
BB TRIP +24V NO BB TRIP +24V NC	4 2	1 3	CN20
DI2-COMMOMN PORT DI2 EXT BB CONTACT SIGNAL	4 2	1 3	CN22
DI1-COMMOMN PORT DI1-REMOTE ON	4 2	1 3	CN23
DI4-COMMOMN PORT DI4 REMOTE SHUTDOWN	4 2	1 3	
DI3-EMERGENCY CUTOFF DI3-COMMOMN PORT	4 2	1 3	
DO1-DRY CONTACT UPS FAULT DO1-COMMOMN PORT	4 2	1 3	
DO3-DRY CONTACT UPS BATTLOW DO3-COMMOMN PORT	4 2	1 3	

The output dry contacts only provide two passive statuses: short and open. It's necessary to connect external power source to trigger this function.

The input dry contacts provide active signals and it's not necessary to connect external power to trigger it. Users can simply short or open the ports to ground.

The detailed electrical parameters of contacts are listed as below:

Dry Contacts	Parameters	Typical	Maximum
Output	Voltage (V)	24VDC	230VAC
	Current (mA)	0.5	1
Input	Voltage (V)	N/A	5
	Current (mA)	N/A	15

### Application:

- Output dry contact

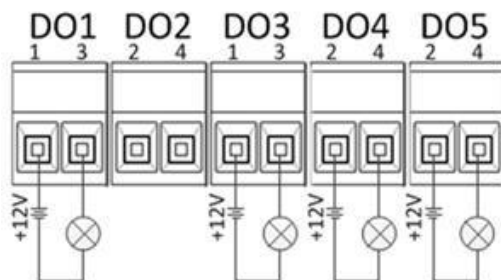

- Input dry contact

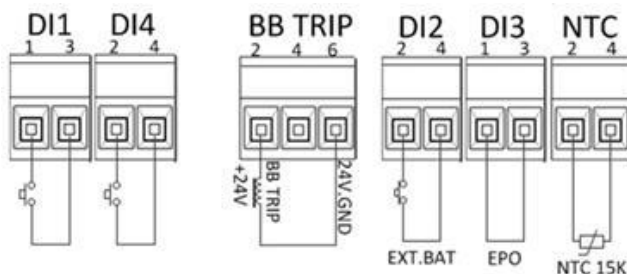

## Function descriptions of output contacts:

### ➤ Output dry contact

Terminals	Function descriptions	Defaults
DO1	0: Normally open 1: Normally closed	0
DO2	0: off 1: Common alarms 2: Normal mode	0
DO3	3: Battery mode 4: Static bypass 5: Output overload 6: Fan failure	0
DO4	7: Battery failure 8: The battery is disconnected 9: Battery voltage is low 10: Input overrun	0
DO5	11: Bypass overrun 12: Emergency stop is activated 13: Maintenance mode 14: Turn on the backfeed protection when inputting 15: Turn on the backfeed protection when bypassing	0

### ➤ Input dry contact

Terminals	Function descriptions	Defaults
DI1	0: Normally open 1: Normally closed 0: Closed 1: UPS is on 2: UPS is off 3: Battery failure 4: The generator set is activated	0
DI4	5: Custom alarm 1 6: Custom alarm 2 7: Disable ECO 8: Forcibly shut down the inverter	0
DI2	External battery contact signal	fixed
DI3	Emergency shutdown (EPO)	fixed
NTC	External battery temperature	fixed
BB TRIP	Battery circuit breaker tripped	fixed

### 4.2.3 EPO

Emergency Power Off (EPO) is the capability to shut down a system. It contains two pins of terminal strip. When it's in open circuit, it will activate shutdown of the system and cut off output. When it's in close status for UPS normal operation.

### 4.2.4 USB/RS232

To allow for unattended UPS shutdown/start-up and status monitoring, connect the bundled USB communication cable one end to the USB port and the other to the communication port of your PC. With the monitoring software installed, you can monitor UPS status through PC. RS232 can select the corresponding wire according to the actual situation of the user for short-distance monitoring.

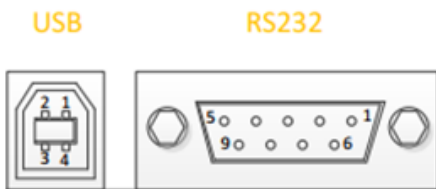

Pin	Function definition
USB	PIN1:VDD
	PIN2:D-
	PIN3:D+
	PIN4:GNDT
RS232	PIN2:RXD
	PIN3:TXD
	PIN5:GNDT

### 4.2.5 RS485

#### ➤ Definition of RS485 pins :

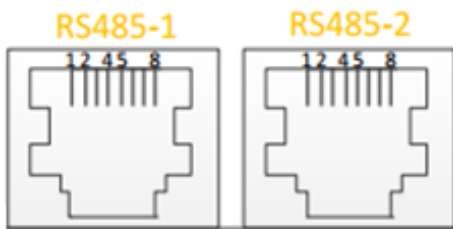

Pin	Function definition
RS485-1	PIN1:485-A
	PIN2:485-B
	PIN4:485-B
	PIN5:485-A
	PIN8:GNDT
RS485-2	PIN1:485-A
	PIN2:485-B
	PIN4:485-B
	PIN5:485-A
	PIN8:GNDT

#### ➤ Application description:

The user can use the network cable as the RS485 connection cable, one end is crimped RJ45 directly connected to the UPS, and the other end is the user end. The connection method can be selected according to the actual situation. Each UPS provides 2 same ports, multiple UPSs can be connected in sequence, and the last one is connected, and multiple UPSs can be monitored at the same time.

## 5. Commissioning

### 5.1 Startup procedure

This series of UPS can support battery cold start startup, but we still recommend users to complete startup according to the following steps:

- Please follow the instructions in Chapter 4 to complete the input and output connections of the UPS, and confirm that all input sources and load parameters meet the UPS specifications. This series is operated by a color touch screen.

**Caution!** This UPS can only be turned on while connecting to battery and utility input.

- Switch on line input, bypass input and battery switch. UPS will start up automatically.
- Wait for the UPS self-checking, LCD screen displays the main page;
- Then, touch the icon "CONTROL" and touch the icon "ON/OFF UPS", confirm UPS is on.
- After entering the "Real-time Control" menu, click "Turn on/Off UPS", and then select "Yes" to confirm after popping up "Turn on UPS";
- When UPS turns on successfully, switch on output switch and supply power to the load.

#### **Cold start procedure:**

When line input is lost, users can follow the steps below to start up the UPS:

- Switch on battery breaker and press cold start button located on the top of front panel for a while, until LCD lighting.
- Wait for the UPS to complete the self-check, the LCD screen displays the main page;
- The subsequent steps are the same as the normal startup steps.

**Caution!** When bypass mode is enabled, the UPS will transfer to bypass mode automatically if bypass input is OK. The UPS won't transfer to line mode until you enter LCD main screen to turn on the UPS.

### 5.2 Shutdown procedure

- Touch the icon "CONTROL" to enter main screen.
- touch the icon "ON/OFF UPS", confirm UPS is off.
- If bypass mode is enabled and bypass input is OK, the UPS will transfer to bypass mode. Otherwise, the UPS will stay in standby mode. When line input is lost, the UPS will transfer to power off mode and shut down after a while.
- After the UPS shuts down completely, switch off line input breaker and battery switch.
- Switch off bypass input breaker and load switch.

### 5.3 Maintenance bypass operation

- Turn off the UPS and keep the UPS working in bypass mode.
- Remove the metal cover of maintenance bypass breaker and then switch on maintenance bypass breaker.
- Switch off line input breaker and battery switch.
- Switch off bypass input breaker. When the UPS works in maintenance bypass mode, the load is still working without interruption.
- After the maintenance is completed, switch on battery switch, AC input breaker and bypass input breaker in order. And then switch off maintenance bypass breaker. Don't forget to put the cover back.

## 6. Interface

### 6.1 Battery test

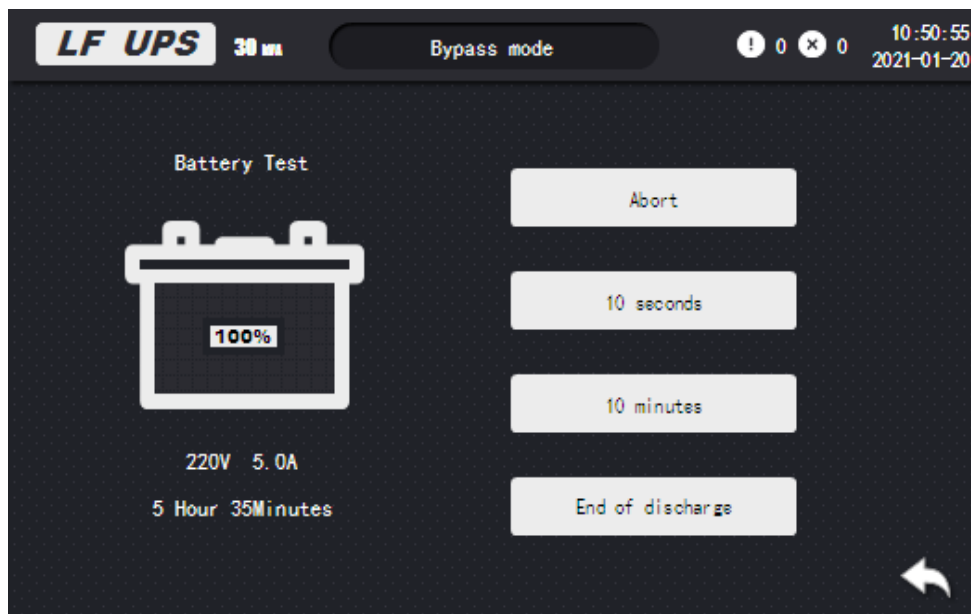

The battery test is used to detect the working condition of the battery:

- On the main screen of the display, select "Control"> "Battery Self Test"
- There are 2 optional tests:
  - 10 seconds: the battery discharges for 10 seconds.
  - 10 minutes: the battery is discharged for 10 minutes.
- Discharge termination: discharge the battery until it reaches the discharge termination voltage.
- Click OK to start the battery self-test.
- Click Stop to stop the battery test, and then click OK to stop the test.

## 6.2 Language settings

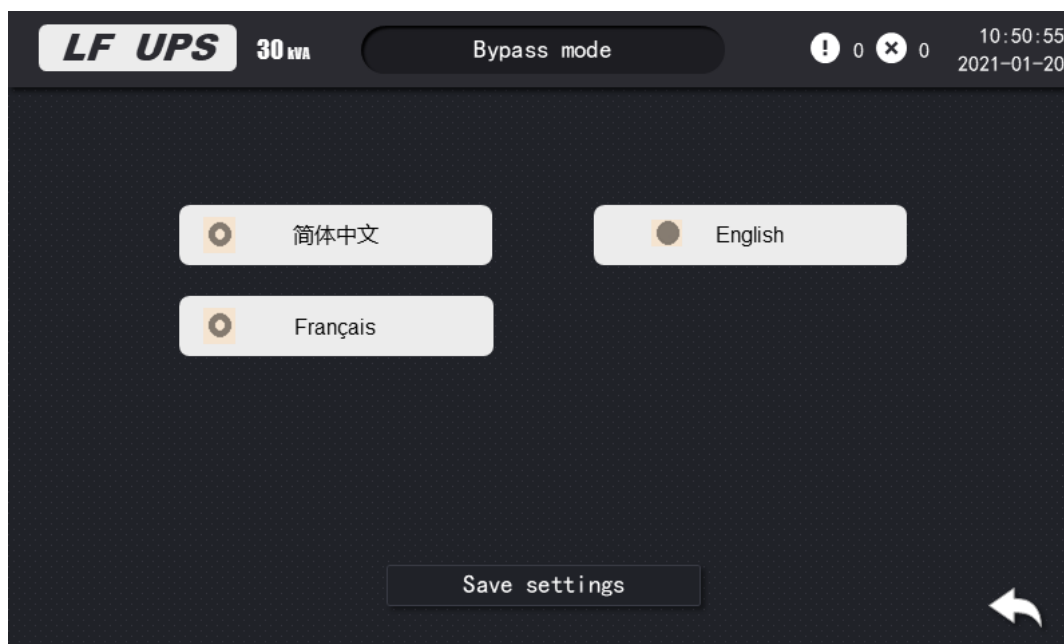

- On the main screen of the display, select "Settings> General Settings> Language Settings".
- Select the desired language.
- Click to save the settings.

## 6.3 Date & time settings

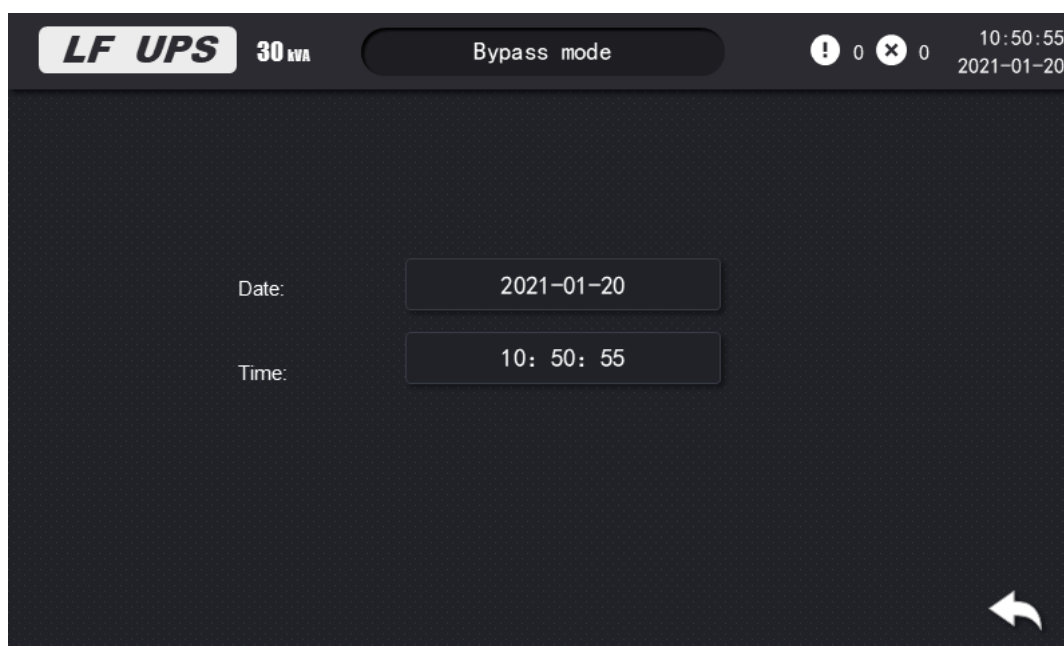

- On the main screen of the display, select "Settings> General Settings> Date and Time".
- Use the keyboard to set the date.
- Use the keyboard to set the time.
- Tap Save settings.

## 6.4 Configure display settings



- On the main screen of the display, select "Settings> General Settings> Display Settings".
- Slide the indicator to the desired setting, and then tap Save settings.

## 6.5 Change the display password

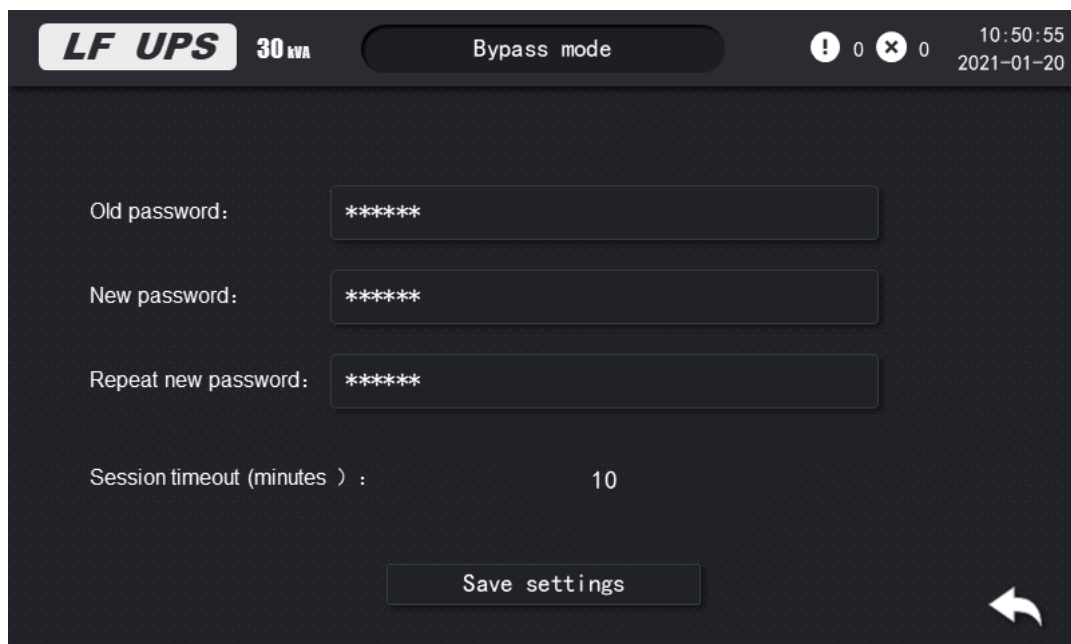

- On the main screen of the display, select "Settings> General Settings> Password Settings".
- Enter the old password.

- Enter the new password and repeat the new password.
- Set the inactive time (minutes) before the display automatically logs out. The selectable range is 0 ~ 120.
- Tap Save settings.

## 6.6 Network settings



- On the main screen of the display, select "Settings> General Settings> Network Settings".
- Set Modbus ID, the optional range is 1-247.
- Set the Modbus baud rate for communication: use the arrow keys to set. Optional range is 2400, 4800, 9600 and 19200.
- Select whether the RS485 port connection should be enabled or disabled.
- Tap Save settings.

## 6.7 Display Calibration

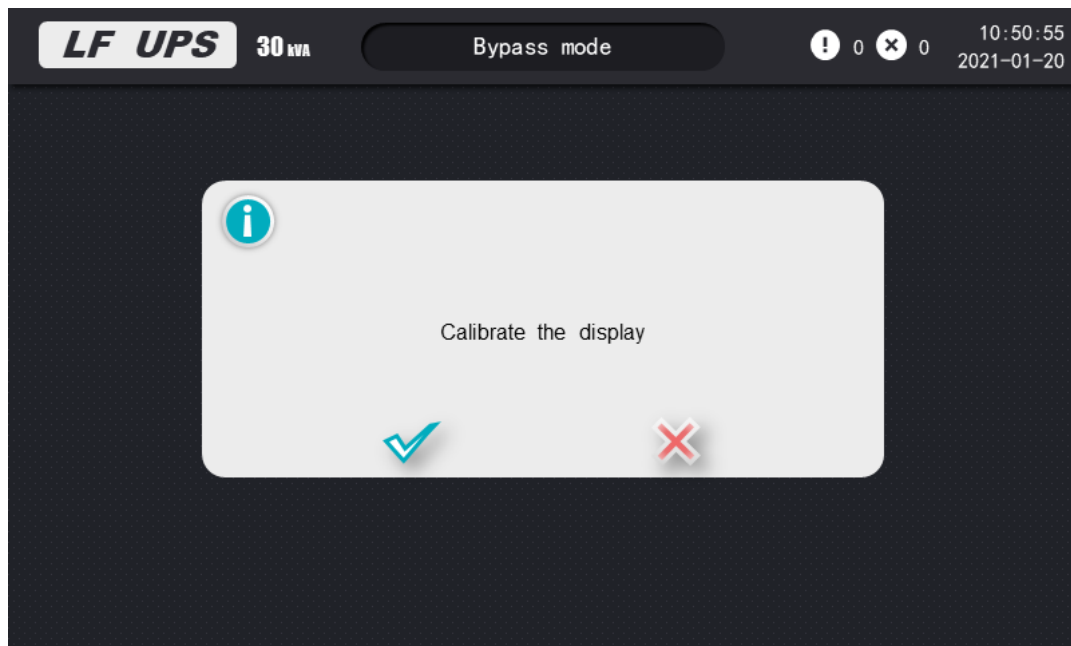

- Select "Settings> General Settings> Display Calibration" and click OK.
- Click the cross mark on the display to complete the calibration.

## 6.8 Parameter settings

<b>Caution !</b>
Beware of equipment damage. Only trained personnel can modify UPS system parameters. Failure to follow the instructions may cause serious consequences such as equipment damage.



- On the main screen of the display, select "Settings>UPS Settings>Parameter Settings.
- Select the input source. Select "Line" or "Generator".
- Set the output rated voltage. The available options are 220V, 230V and 240V.
- Set the output rated frequency. The available options are 50Hz and 60Hz.
- Tap Save settings.

## 6.9 Battery Settings

### Caution !

Beware of equipment damage.  
Only trained personnel can modify UPS system parameters. Failure to follow the instructions may cause serious consequences such as equipment damage.

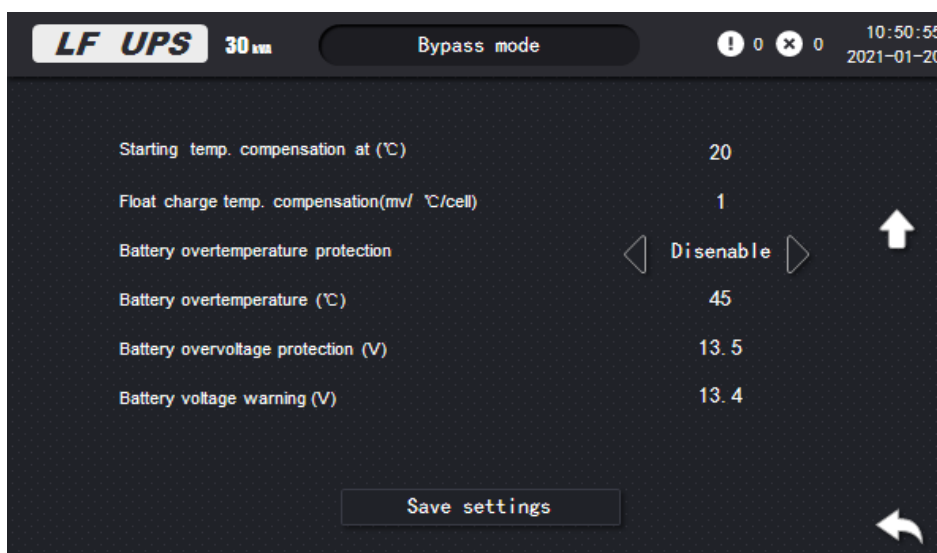
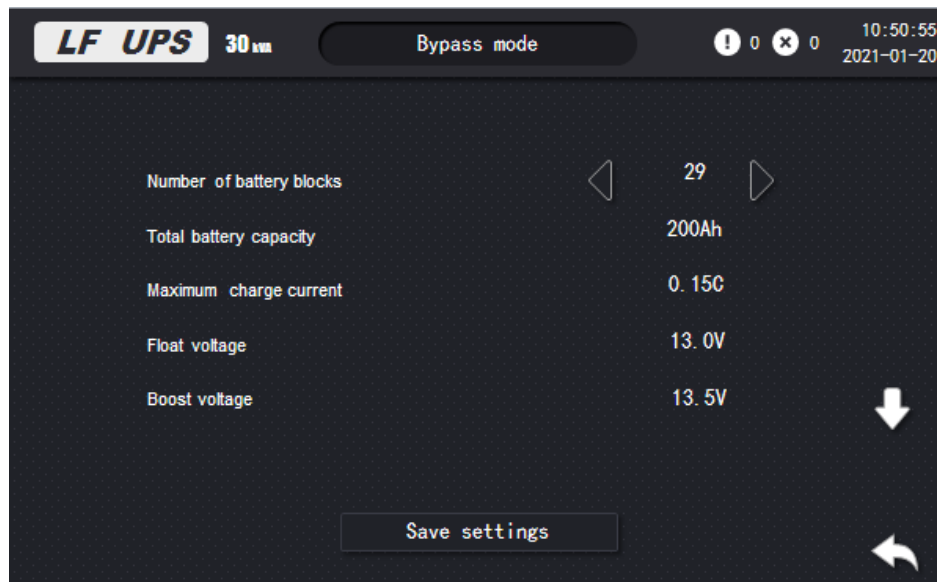

- On the main screen of the display, select "Settings> UPS Settings> "Number of battery blocks.
- Set the number of battery blocks contained in each battery pack.
- Set the total battery capacity (Ah).
- Set the maximum charging current. The selectable range is 0.1C -0.2C.
- Tap Save settings.
- Click down arrow
- Starting temp. compensation at (°C): The optional range is 20-25°C .
- Float charge temp. compensation (mv/°C/cell): The selectable range is 0-7.
- Select whether to enable or disable the battery overtemperature protection. If enabled, make the following settings:
  - Battery temperature (°C): The selectable range is 40-45 °C.
  - Battery overvoltage protection (V): The selectable range is 13-15 V. c. Battery voltage warning (V): The selectable range is 13 -15 V.
- Tap Save settings.

## 6.10 Mode settings

**Caution !**

Beware of equipment damage.  
Only trained personnel can modify UPS system. Failure to follow the instructions may cause serious consequences such as equipment damage.

1. On the main screen of the display, select "Settings>Advanced Settings>Mode Settings" and make the following settings.

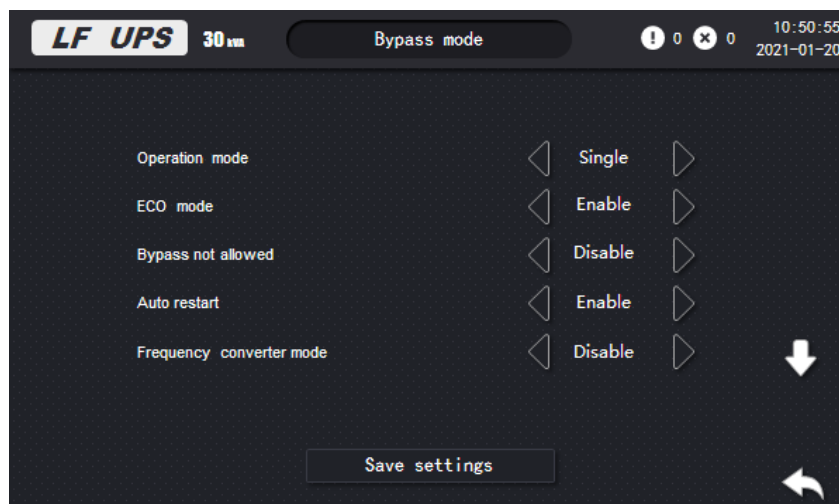

- Operation mode: select Single or Parallel.
- ECO Mode: Select whether ECO mode should be enabled or disabled.
- Bypass not allowed: After enabling this setting, the UPS will not be allowed to switch to bypass operation mode.
- Auto restart: Choose whether to enable or disable auto restart.
- Frequency converter mode: Select whether the frequency converter mode should be enabled or disabled.

2. Tap Save settings.

3. Click the down arrow and configure the following:

<b>Caution !</b>
<p>Beware of equipment damage          If this function is disabled, the UPS may be damaged.          Failure to follow the instructions may cause serious consequences such as equipment damage.</p>

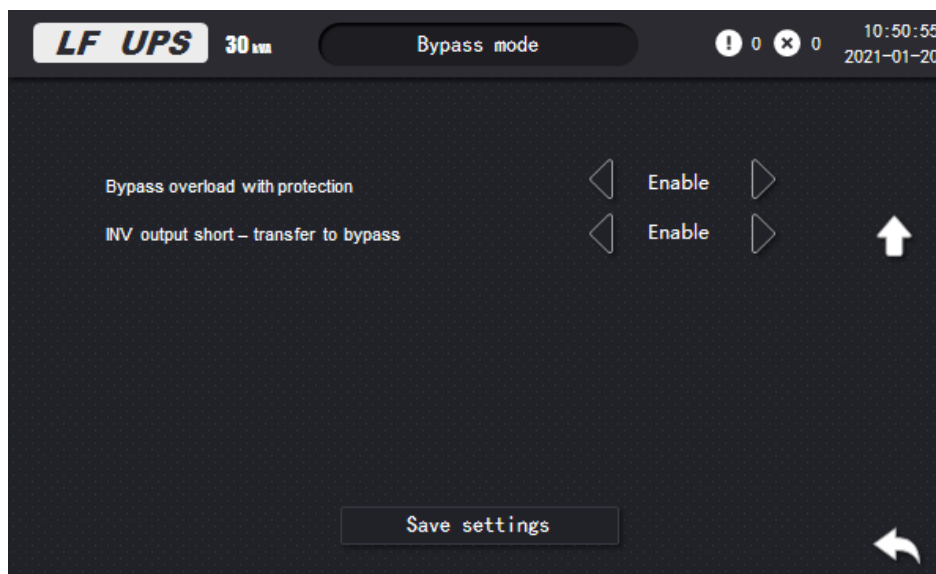

- Bypass overload with protection: After enabling this setting, the UPS will cut off the output when bypass overload occurs to protect the UPS.
- INV output short - transfer to bypass: After enabling this setting, the UPS will switch to bypass when an inverter output short-circuit occurs instead of disconnecting the output.

2. Tap Save settings.

## 6.11 Parallel settings

<b>Caution !</b>
Beware of equipment damage. Only trained personnel can modify UPS system parameters. Failure to follow the instructions may cause serious consequences such as equipment damage.

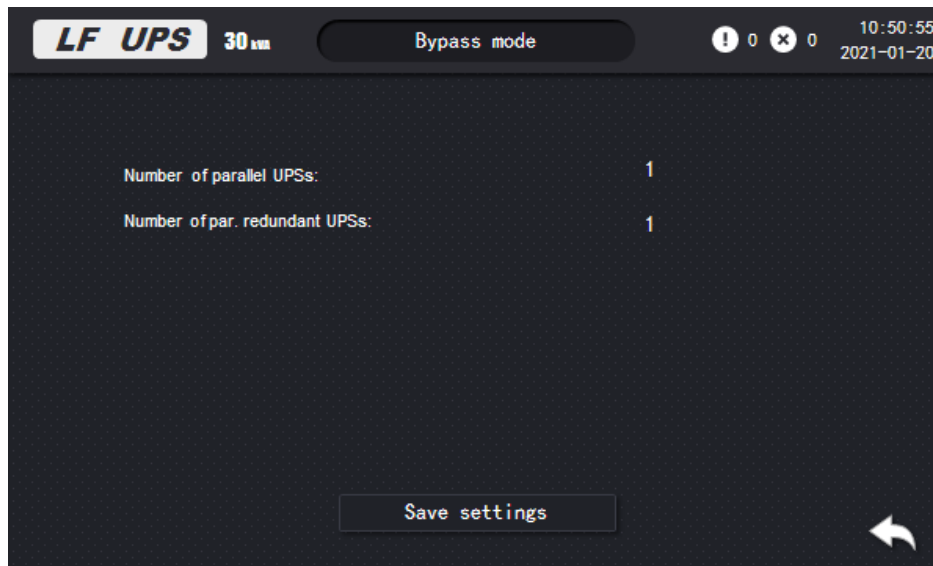

- On the main screen of the display, select "Settings> Advanced Settings> Parallel.
- Set the number of parallel UPSs. The selectable range is 2-4.
- Set the number of par. redundant parallel UPSs. The selectable range is 0 ~ 3.
- Click to save the settings.

## 6.12 Battery test settings

<b>Caution !</b>
Beware of equipment damage. Only trained personnel can modify UPS system parameters. Failure to follow the instructions may cause serious consequences such as equipment damage.

On the main screen of the display, select "Settings> Advanced Settings> Battery test.

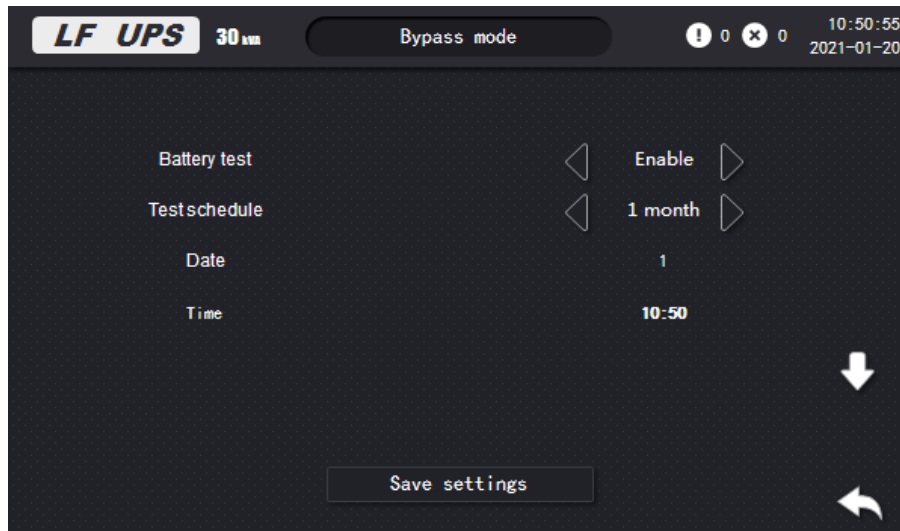

Choose whether the automatic battery test should be enabled or disabled. If enabled, make the following settings:

- Test schedule: Choose whether the battery test interval should be set to monthly or weekly. If you select monthly, set the date when the battery test should be performed. If every week is selected, set the week when the test should be performed.
- Date: Set the time of the date for battery test.
- Click to save the settings.
- Click the down arrow.

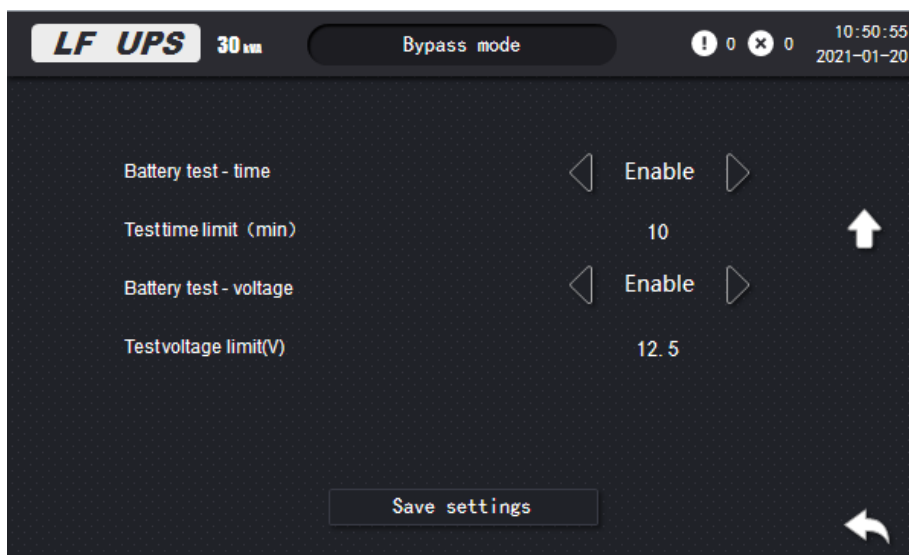

- Set battery test - time: Select Enable to manually specify the test time limit for battery test.
- Set battery test - voltage: Select Enable to manually specify the test voltage limit for battery test.
- Click to save the settings.

## 6.13 Dry contact settings

On the main screen of the display, select "Settings> Advanced Settings> Input Dry Contact", and then select the input dry contact to be configured. Configure the following parameters of the input dry contact:

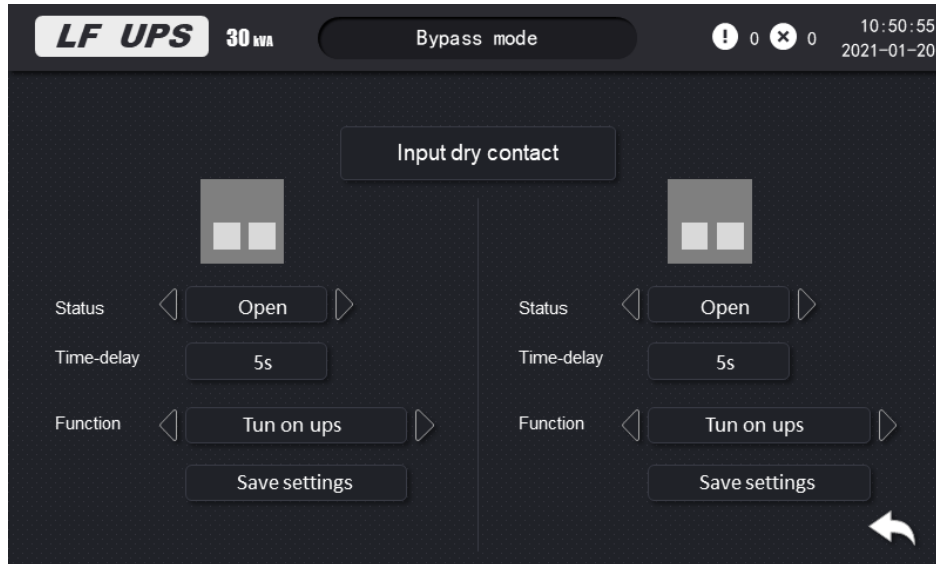

- Status: Set whether the input dry contact should be open or close.
- Time-delay: Set the activation delay (seconds) of the input dry contact.
- Function: Select the function of input dry contact. The available options are disabled, INV on, INV off, battery failure,
- Generator set on, custom alarm 1, custom alarm 2, disable ECO, INV forcibly shut down.
- Click Save settings to save.

## 6.14 Output dry contact settings

On the main screen of the display, select "Settings> Advanced Settings> Output Dry Contact", and then select the output dry contact to be configured. Configure the following parameters of the input dry contact:

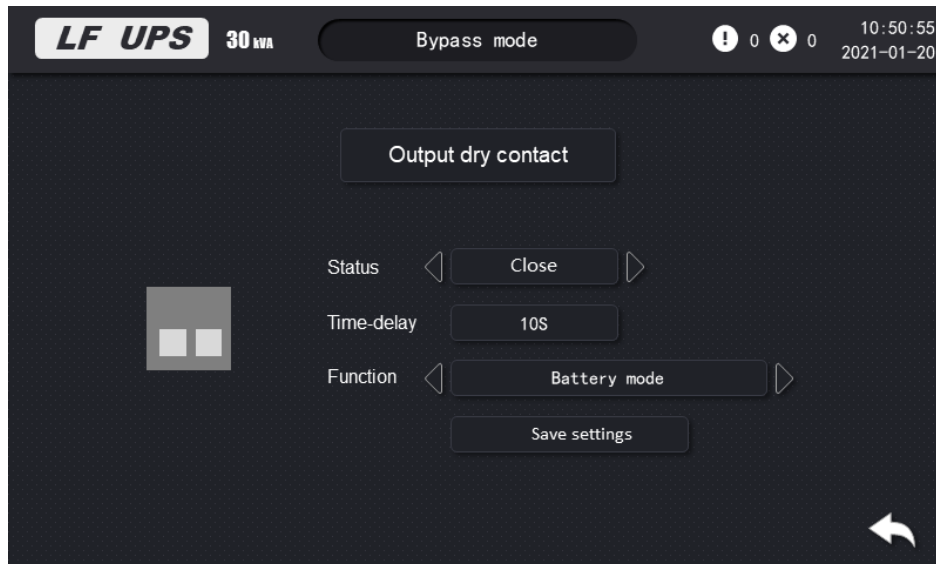

- Status: Set whether to open or close the output dry contact.
- Time-delay: Set the activation delay (seconds) of the output dry contact.
- Function: select the function of output dry contact. Available options are disable, common alarm, normal operation mode, battery mode
- Mode, static bypass, output overload, fan failure, battery failure, battery disconnected, low battery voltage, input overrun, bypass overrun, emergency shutdown activation, maintenance bypass, charging, M1 backfeed, M2 backfeed.
- Click Save settings to save.

## 6.15 Fault alarm

- On the main screen of the display, select "Alarm".
- Choose whether to view warning information or fault information.

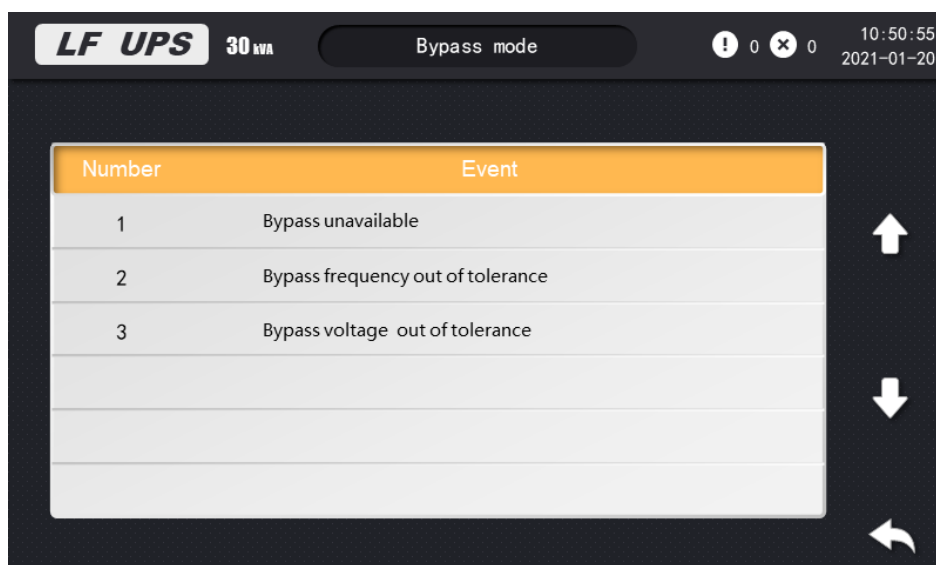

- Use the arrow keys to browse the event alarms in the list.

## 6.16 Clear event log

- On the main screen of the display, select "Settings> Advanced Settings> Initialization> Clear Event Log".
- Click OK to clear the event log or click Cancel to abort.

## 6.17 Clear settings log

- On the main screen of the display, select "Settings> Advanced Settings> Initialization> Clear Settings Log".
- Click OK to clear all logs or click Cancel to abort.
- On the main screen of the display, select "Services> Export Data to USB flash drive".
- Open the front cover of the UPS and insert the USB flash drive into the USB port on the display.
- Select "Export Event Log" or "Export Settings Log".
- The screen will display the stored log entries and the total number of log entries.
- Click Export to export the log to the USB flash drive.

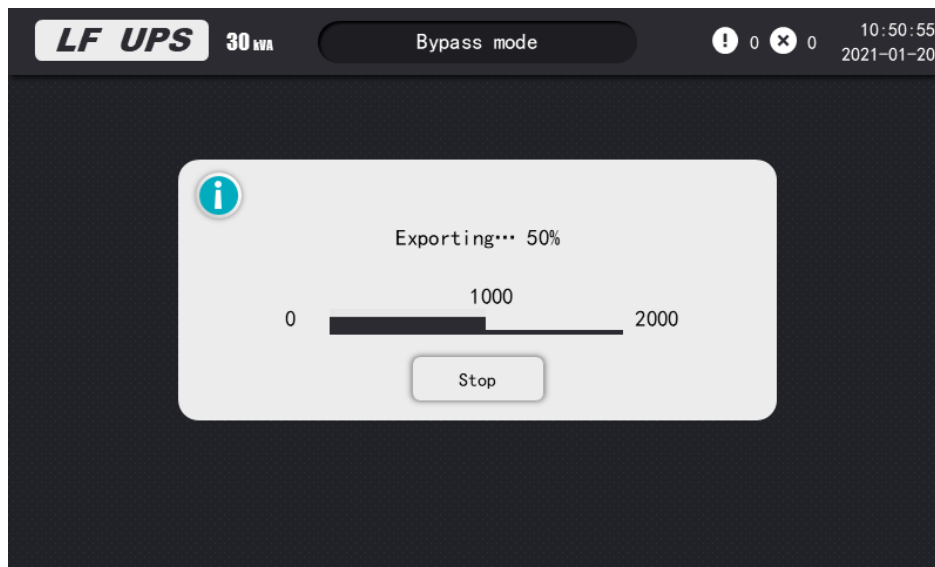

- Unplug the USB flash drive from the USB port.

## 6.19 Clear fault status

When the UPS is in a fault state, the fault state must be cleared before starting the UPS.

- On the main screen of the display, select "Control> Clear Fault Status".
- Click OK to clear the fault status.

## 7. Maintenance

**Caution! Inside maintenance is only available for the engineer with qualified electrical knowledge. There is still possible high voltage inside of the unit even disconnect all connections. Opening the UPS side cover by non-professionals may cause personal injury and equipment damage.**

### 7.1 System maintenance

- Check if indicators and LCD function well and the buttons are functional.
- Make sure there is no abnormal noise inside of the unit.
- Make sure nothing blocks the ventilation of the unit.
- Please use dry towel to clean the surface of the unit when it is not working.
- Please check the outlook condition of all wires and connection situation periodically after disconnecting all power. The checking interval should be less than 2 years.

### 7.2 Battery maintenance

In order to prolong the lifecycle of the battery, please do the maintenance periodically.

- The lifecycle of the battery is based on ambient temperature and recharge cycles. Please make the battery working under the ambient temperature between 15°C ~25°C.
- Check the voltage of the battery pack weekly. Check the voltage of each battery monthly.
- Keep the environment of battery clean and tidy.
- Check the terminals of the batteries termly, make sure they are tightened.
- Please charge the battery once a month if the battery hasn't been used for a long time.
- If the discharging time is much less than normal situation, please check if it's time to replace them.

## 8. Trouble shooting

### 8.1 Warning code

Code	Event	How to do
01	Battery open	Please check if battery wires are connected correctly and battery switch is on.
03	Line phase error	Please check the phase sequence of line input.
04	Bypass phase error	Please check the phase sequence of bypass
05	Battery over charge	Check the battery voltage and then restart the unit.
06	Low battery	Remove all connected loads and charge the battery from utility.
08	EPO active	EPO is activated. Please refer to 4.2.3 to disable it.
24	Capacity mode (N+0)	Check UPS load
48	The battery voltage is lower than the shutdown voltage	Check the battery voltage and restart the UPS.
29	Unstable bypass frequency	Check whether the bypass input frequency is within the normal range.
14	MBB closed	Check maintenance bypass switch
17	Remaining backup time	Check the battery voltage and restart the UPS.
19	Battery test is not completed	Check the battery voltage and restart the UPS.
52	Output overload warning	Check UPS load
53	Bypass overload warning	Check UPS load
69	Bypass abnormal	Check the bypass input power
70	Input is not available	Check input power
54	MBB used incorrectly	Check maintenance bypass switch
22	Parallel cables are damaged	Check the parallel line
55	Input frequency exceeds limit	Check whether the input frequency is within the normal range.
56	Input voltage exceeds limit	Check the bypass power supply
57	Bypass is out of sync	Check the bypass power supply
75	Fan failure	Check the fan
21	Inverter is out of sync	Check the bypass power supply
66	Battery over temperature warning	Check the battery
63	Control board over temperature warning	Reduce the load or lower the working environment temperature of the UPS.
60	REC1 SCR over	Reduce the load or lower the working

	temperature warning	environment temperature of the UPS.
59	Charger SCR over temperature warning	Reduce the load or lower the working environment temperature of the UPS.
61	Inverter SCR over temperature warning	Reduce the load or lower the working environment temperature of the UPS.
62	Bypass SCR over temperature warning	Reduce the load or lower the working environment temperature of the UPS.
64	IGBT1 over temperature warning	Reduce the load or lower the working environment temperature of the UPS.
65	IGBT2 over temperature warning	Reduce the load or lower the working environment temperature of the UPS.
67	REC2 SCR over temperature warning	Reduce the load or lower the working environment temperature of the UPS.
18	BB disconnect	Check the battery switch
34	Warranty is about to expire	Contact repair service
35	Warranty has expired	Contact repair service
39	Check the battery	Contact repair service
38	Check the filter	Contact repair service
37	Check AUX PSU	Contact repair service
36	Check AC capacitor	Contact repair service
40	Check DC capacitor	Contact repair service
41	Check the fan	Contact repair service
71	EEPROM failure	Restart the UPS, if the problem is not resolved, contact the maintenance service.
72	No bypass allowed	Check UPS settings
73	Bypass frequency exceeds limit	Check the bypass power supply
74	Bypass voltage exceeds limit	Check the bypass power supply
77	Turn on the backfeed protection when bypassing	Check bypass SCR
76	Turn on the backfeed protection when input	Check rectifier SCR
79	Wrong number of parallel devices	Check the parallel quantity setting of each UPS in the parallel system
80	Failed three times	Check event log
23	Parallel bypass input is inconsistent	Check the bypass power supply and bypass switch
81	Output switch is off	Check the output switch
82	SPS abnormal	Check the power board
98	REC1 SCR over temperature	Reduce the load or lower the working environment temperature of the UPS.
97	Charger SCR over temperature	Reduce the load or lower the working environment temperature of the UPS.

99	Inverter SCR over temperature	Reduce the load or lower the working environment temperature of the UPS.
100	Bypass SCR over temperature	Reduce the load or lower the working environment temperature of the UPS.
102	IGBT1 over temperature	Reduce the load or lower the working environment temperature of the UPS.
103	IGBT2 over temperature	Reduce the load or lower the working environment temperature of the UPS.
101	Control board over temperature	Reduce the load or lower the working environment temperature of the UPS.
105	Input inductor/transformer over temperature	Reduce the load or lower the working environment temperature of the UPS.
106	INV transformer over temperature	Reduce the load or lower the working environment temperature of the UPS.
104	REC2 SCR over temperature	Reduce the load or lower the working environment temperature of the UPS.

## 8.2 Fault code

1	DC bus soft start failed	Restart the UPS, if the problem is not resolved, contact the maintenance service.
2	DC bus overvoltage	Restart the UPS, if the problem is not resolved, contact the maintenance service.
3	DC bus undervoltage	Restart the UPS, if the problem is not resolved, contact the maintenance service.
17	INV soft start failed	Restart the UPS, if the problem is not resolved, contact the maintenance service.
18	INV high voltage	Restart the UPS, if the problem is not resolved, contact the maintenance service.
19	Low INV voltage	Restart the UPS, if the problem is not resolved, contact the maintenance service.
20	L1 INV short circuit	Disconnect the load and restart the UPS. Please check the load.
21	L2 INV short circuit	Disconnect the load and restart the UPS. Please check the load.
22	L3 INV short circuit	Disconnect the load and restart the UPS. Please check the load.
23	L1-2 INV short circuit	Disconnect the load and restart the UPS. Please check the load.
24	L2-3 INV short circuit	Disconnect the load and restart the UPS. Please check the load.
25	L3-1 INV short circuit	Disconnect the load and restart the UPS. Please check the load.
83	L1 INV overcurrent	Disconnect the load and restart the UPS. Please check the load.
84	L2 INV overcurrent	Disconnect the load and restart the UPS. Please check the load.
85	L3 INV overcurrent	Disconnect the load and restart the UPS. Please check the load.
37	Wiring error	Check UPS input and output external wiring
38	Switch action line lost	Restart the UPS, if the problem is not resolved, contact the maintenance service.
39	Parallel cables are missing	Check the parallel line
40	CAN communication lost	Restart the UPS, if the problem is not resolved, contact the maintenance service.
41	Parallel host line is lost	Check the parallel line
42	Parallel UPS output voltage does not match	Check the output voltage settings of each UPS in the parallel system
44	INV switch to bypass timeout	Check the bypass power supply
45	Bypass switch to INV timeout	Check the bypass power supply

46	Incompatible parallel version	Restart the UPS, if the problem is not resolved, contact the maintenance service.
47	Parallel sync line is lost	Restart the UPS, if the problem is not resolved, contact the maintenance service.
66	CPU communication lost	Restart the UPS, if the problem is not resolved, contact the maintenance service.
67	Overload serious incident	Restart the UPS, if the problem is not resolved, contact the maintenance service.
72	DSP firmware is not compatible	Restart the UPS, if the problem is not resolved, contact the maintenance service.
82	Battery voltage is too high	Check the battery voltage and restart the UPS.
86	L1 output overcurrent	Disconnect the load and restart the UPS. Please check the load.
87	L2 output overcurrent	Disconnect the load and restart the UPS. Please check the load.
88	L3 output overcurrent	Disconnect the load and restart the UPS. Please check the load.
89	L1 INV SCR failure	Restart the UPS, if the problem is not resolved, contact the maintenance service.
90	L2 INV SCR failure	Restart the UPS, if the problem is not resolved, contact the maintenance service.
91	L3 INV SCR failure	Restart the UPS, if the problem is not resolved, contact the maintenance service.
92	L1 bypass SCR failure	Restart the UPS, if the problem is not resolved, contact the maintenance service.
93	L2 bypass SCR failure	Restart the UPS, if the problem is not resolved, contact the maintenance service.
94	L3 bypass SCR failure	Restart the UPS, if the problem is not resolved, contact the maintenance service.
107	The number of parallel UPS settings does not match	Check UPS parallel settings
108	The output frequency of parallel UPS does not match	Check UPS parallel settings

## 9. Specification

Table1: Line input

Model	LF33 10	LF33 20	LF33 30	LF33 40	LF33 60	LF33 80	LF33 100	LF33 120	LF33 160	LF33 200	LF33 250	LF33 300
Capacity	10K VA	20K VA	30 KVA	40K VA	60K VA	80K VA	100K VA	120K VA	160K VA	200K VA	250K VA	300K VA
	8KW	16K W	24 KW	32 KW	48 KW	64 KW	80 KW	96 KW	128 KW	160 KW	200 KW	240 KW
Connection	L1、L2、L3、PE											
Rated voltage	3 x 380VAC/400VAC/415VAC(3Ph + N)											
Rated frequency	50Hz/60Hz											
Voltage range	304V~456VAC (Ph-Ph)											
Frequency range	46Hz~54Hz @50Hz											
Rated input current / per phase	20A	38A	55A	72A	108A	130A	160A	200A	250A	320A	416A	547A

Table 2: Battery

Model	LF33 10	LF33 20	LF33 30	LF33 40	LF33 60	LF33 80	LF33 100	LF33 120	LF33 160	LF33 200	LF33 250	LF33 300
Battery numbers	29~32 PCS (12V in series)											
Rated voltage	348~384VDC											
Charging current	The charging current depends on the battery capacity. The default is 0.1 C											
Float voltage	13.5VDC / per block (12V)											
High voltage protection	14.5VDC / per block (12V)											
Full load discharge termination voltage	304VDC											
Temperature compensation	-3.3 mV/°C ( T ≥ 25 °C 时 ) · 0 mV/°C ( T < 25 °C 时 ) /per block											

Table 3: Inverter output

<b>Model</b>	LF33 10	LF33 20	LF33 30	LF33 40	LF33 60	LF33 80	LF33 100	LF33 120	LF33 160	LF33 200	LF33 250	LF33 300
Connection	L1、L2、L3、N、PE											
Output waveform	Sinusoidal wave											
Rated voltage	3 x 380VAC/400VAC/415VAC (3Ph + N)											
Tolerance	±1% (Balanced)											
Rated frequency	50 Hz ±1 %											
THDV	100% linear load <2%; 100% non-linear load <4%											
Overload capacity	≤110% continuous operation, 125% for 10 minutes; 150% for 1 minute											
Power factor	0.8											

Table 4: Bypass

<b>Model</b>	LF33 10	LF33 20	LF33 30	LF33 40	LF33 60	LF33 80	LF33 100	LF33 120	LF33 160	LF33 200	LF33 250	LF33 300
Connection	L1、L2、L3、N、PE											
Rated voltage	3 x 380VAC/400VAC/415VAC (3Ph + N)											
Rated frequency	50Hz											
voltage range	285~475V (Ph-Ph)											
Frequency Range	46Hz~54Hz @50Hz;											
Transfer time	0ms											
Overload capacity	> 150% ~ 180% 1h~5s; > 180% ~ 250% 5s											

Table 5: ECO Bypass (Default disable)

<b>Model</b>	LF33 10	LF33 20	LF33 30	LF33 40	LF33 60	LF33 80	LF33 100	LF33 120	LF33 160	LF33 200	LF33 250	LF33 300
Rated voltage	3 x 380VAC/400VAC/415VAC (3Ph + N)											
Rated frequency	50Hz											
Voltage range	304V~456V (Ph-Ph)											
Frequency range	46Hz~54Hz @50Hz											
Transfer time	<10ms											

Table 6: Environment

<b>Model</b>	LF33 10	LF33 20	LF33 30	LF33 40	LF33 60	LF33 80	LF33 100	LF33 120	LF33 160	LF33 200	LF33 250	LF33 300
Working temperature range	0°C ~ 35°C											
Storage temperature range	-25°C ~ 55°C											
Altitude	0 ~ 1000m											
Humidity	(Please refer to chapter 3.1 when over 1000m)											
IP degree	5% ~ 95% no condensing											
Cooling	IP31											
Communi-cation	Forced air cooling											
Color	RAL7035											

Table 7: Mechanics

<b>Model</b>	LF33 10	LF33 20	LF33 30	LF33 40	LF33 60	LF33 80	LF33 100	LF33 120	LF33 160	LF33 200	LF33 250	LF33 300	
Depth (mm)	800											850	
Width (mm)	800						1200			1600			1630
Height (mm)	1800											1900	
Weight (kg)	290	349	385	427	508	563	760	850	1120	1390	1750	2100	

## 10. Parallel Installation Guide

### 10.1 Introduction

- The UPS can be paralleled in 3+1 redundancy or 4 units as an expansion.
- **N+1 parallel redundancy.** parallel redundancy mode, the total output load should not be greater than N times the rated load of the single UPS. When one of the parallel units fails, the unit can be removed and added into the system freely, the system will continue running without interruption, which improves the reliability of the system; when the output exceeds the load described as above, the overloaded unit (exceeding  $N/N+1$  times the single-unit rating) will issue an alarm and enter the expansion mode. The maximum power in this mode is  $N \times \text{Single-unit capacity}$ , unless special circumstances, generally do not use the parallel connection to increase the total output power. For example: for a two-unit parallel system, when the unit load exceeds 50%, an alarm message will be issued, and the LCD will prompt the machine to enter the expansion mode.
- **Host and slaves** Among several parallel units, the one that is turned on first is the master and the others are slaves. The master-slave relationship can be changed. If one of the units fails, the unit will automatically cut off the output. If the host fails, the host will automatically cut off the output, and the slave will automatically re-select a new host according to the working status of each machine at that time to maintain the system to continue running.

### 10.2 Parallel Kit Overview

#### 10.2.1 Overview

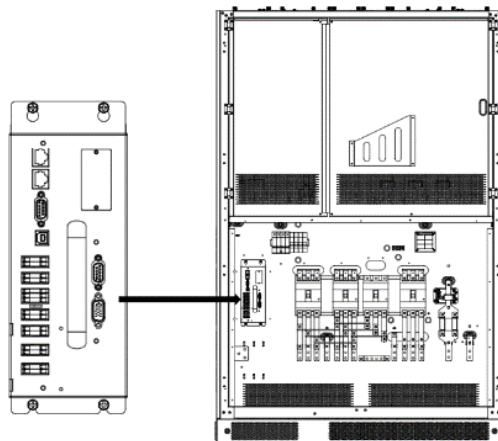

Parallel communication port

## 10.2.2 Package Contents

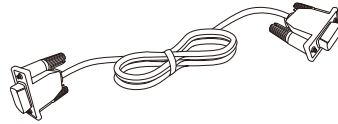

Parallel communication cable

## 10.2.3 Installation

When installing multiple units, please follow below chart.

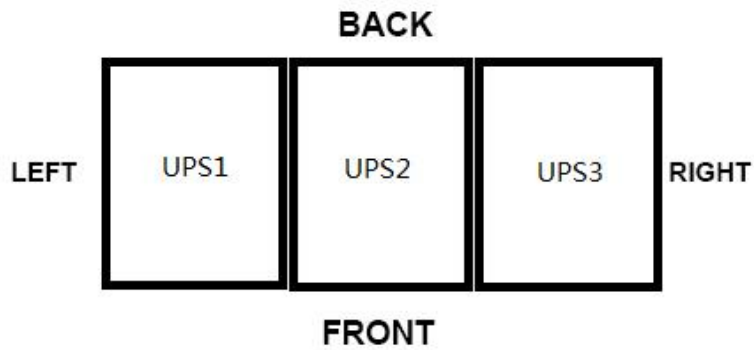

Installation environment space requirements: the front of the UPS is at least 80cm away from the wall or other objects, and the two sides can be side by side with the wall or other objects.

## 10.2.4 Parallel Wiring Connection

- Two UPSs in parallel:

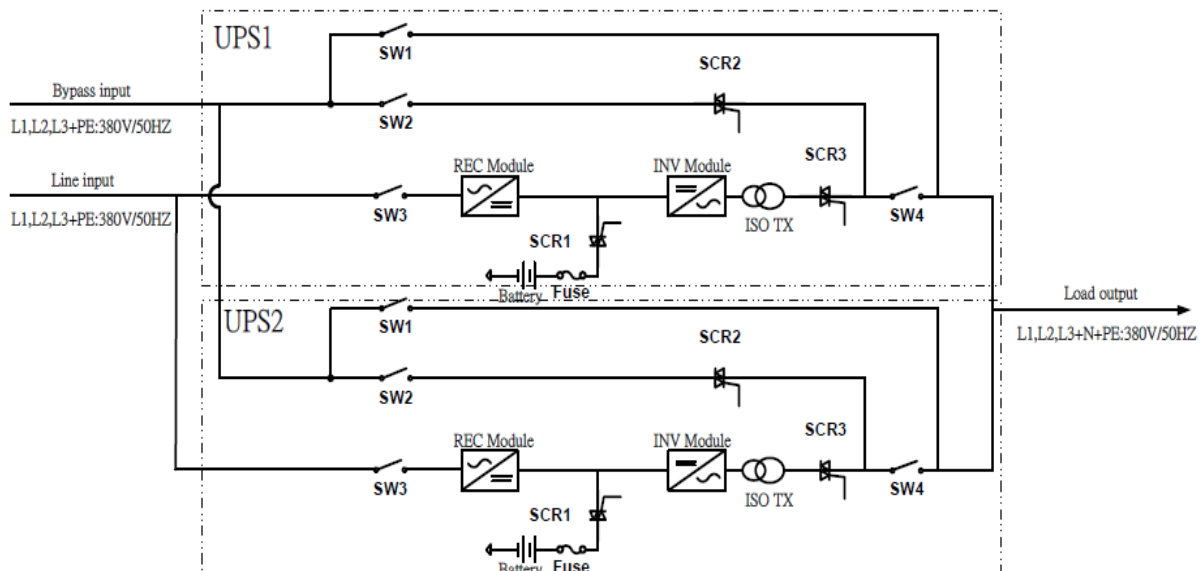

- Communication Connection:

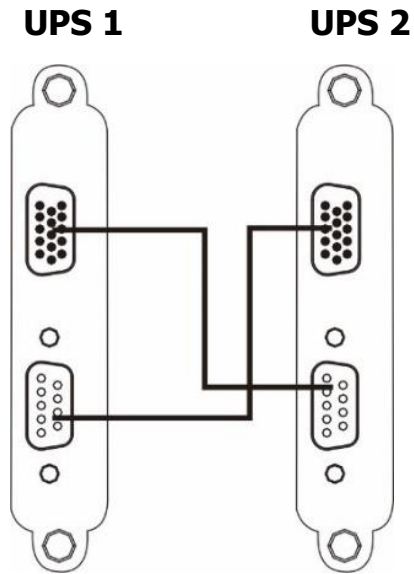

- Three UPSs in parallel:

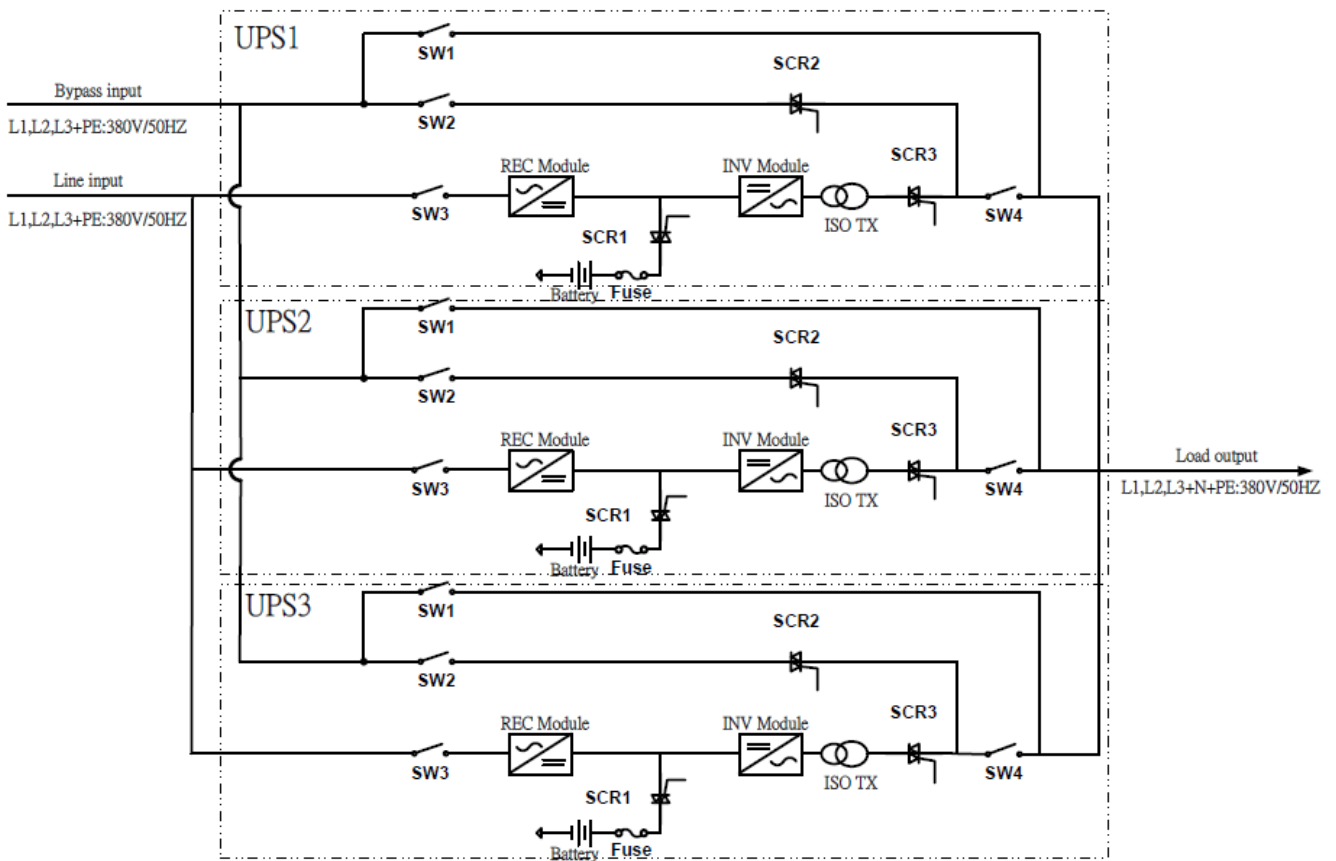

◆ Communication Connection

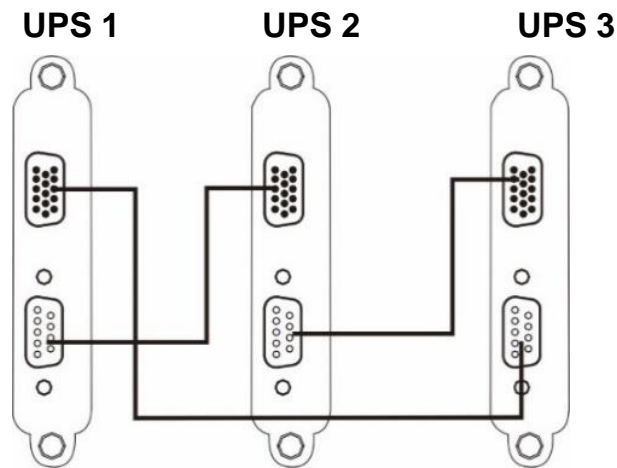

Please apply the same above wiring connection to finish four UPSs in parallel.

Recommended specification of battery breaker for each UPS:

Model	One unit
LF3310	80A/500VDC
LF3320	80A/500VDC
LF3330	100A/500VDC
LF3340	150A/500VDC
LF3360	200A/500VDC
LF3380	250A/500VDC
LF33100	350A/500VDC
LF33120	350A/500VDC
LF33160	400A/500VDC
LF33200	600A/500VDC
LF33250	800A/500VDC
LF33300	1200A/500VDC

**Caution!** Please be sure **NOT** to share the same battery pack in parallel system. It's recommended to use the same specification for all connected batteries.

### 10.3 Parallel setting and LCD display

The UPS defaults to stand-alone mode. If you want to achieve parallel operation, you need to set the LCD operation. This operation must have the service engineering password "XXXX" provided by the service engineer to be set.

- On the main screen of the display, select "Settings> Advanced Settings> Parallel Settings".
- Set the number of parallel UPS. The selectable range is 2-4.
- Set the number of redundant parallel UPSs. The selectable range is 0 ~ 3.
- Click to save the settings.

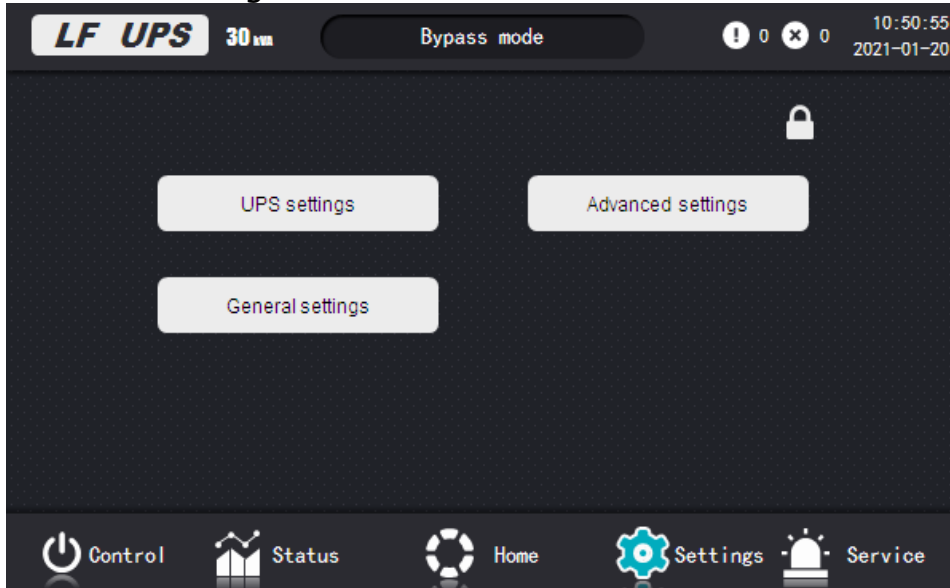

Advanced settings page

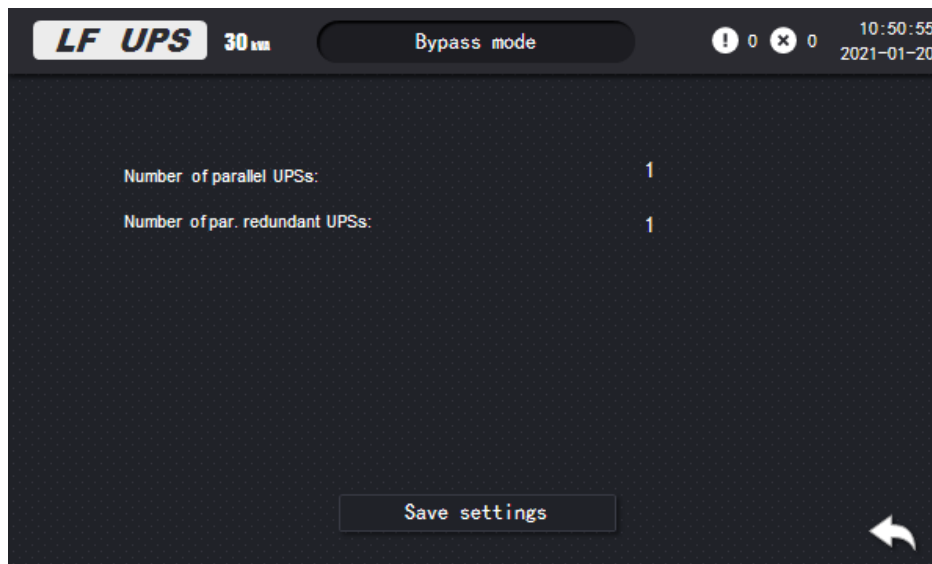

Parallel setting page

### 10.3 Specification

Model	LF3310	LF3320	LF3330	LF3340	LF3360	LF3380
Power range	10KVA /8KW	20KVA /16KW	30KVA /24KW	40KVA /32KW	60KVA /48KW	80KVA /64KW
Max parallel number: 4						
Maximum output power	40KVA/ 32KW	80KVA/ 64KW	120K VA/ 96KW	160K VA/ 128KW	240K VA/ 192KW	320K VA/ 256KW
Circulation Current under No Load	<3A					
Power Unbalance Ratio	<5% @ 100% Load					
Parallel communication	CAN					
Transfer time in parallel mode	0ms					

Model(KVA)	LF33100	LF33120	LF33160	LF33200	LF33250	LF33300
Power range	100KVA /80KW	120KVA /96KW	160KVA /128KW	200KVA /160KW	250KVA /200KW	300KVA /240KW
Max parallel number: 4						
Maximum output power	400K VA/ 320KW	480K VA/ 384KW	640K VA/ 512KW	800K VA/ 640KW	1000K VA/ 800KW	1200K VA/ 960KW
Circulation Current under No Load	<5A					
Power Unbalance Ratio	<5% @ 100% Load					
Parallel communication	CAN					
Transfer time in parallel mode	0ms					

## 10.4 Trouble shooting

### ● Warning code

Code	Event	How to do
22	Parallel line lost	Check if sharing cables are connected well and restart the UPS.
23	Bypass wiring difference	Check if the Bypass phase sequence and voltage is correct or not.
24	N+1 redundancy lost	A single UPS exceeds N/N+1 times the rated capacity of a single unit, prompting the user that the redundant backup mode of the machine has failed, and the user is concerned about the working status of the UPS in real time.

### ● 10.5.2 Fault code

Code	Event	How to do
38	Switch line fault	1. Update all UPS firmware to the same version. 2. After updating, if the problem still remains, please contact your local dealer.
39	Parallel line loss	
40	CAN comm. fault	
41	Host line loss	
42	Output voltage difference	Restart the UPS, if the problem is not resolved, contact the maintenance service.
46	Parallel version difference	Contact maintenance service.
47	SYNC line Loss	Turn off the machine, re-plug the parallel communication line, check the connection is good, and restart the machine.
49	Parallel setting difference	Check if the parameter setting of all UPSs are the same. If not, please update them with same settings.